

ASPM34 Series

Automotive 3-Phase 1200 V, 35 A IGBT Intelligent Power Module

NFVA23512NP2T

General Description

NFVA23512NP2T is an advanced Auto IPM module providing a fully-featured, high-performance inverter output stage for hybrid and electric vehicles. These modules integrate optimized gate drive of the built-in IGBTs to minimize EMI and losses, while also providing multiple on-module protection features including under-voltage lockouts, over-current shutdown, thermal monitoring of drive IC, and fault reporting. The built-in, high-speed HVIC requires only a single supply voltage and translates the incoming logic-level gate inputs to the high-voltage, high-current drive signals required to properly drive the module's internal IGBTs. Separate negative IGBT terminals are available for each phase to support the widest variety of control algorithms.

Features

- Automotive SPM[®] in 34 pin DIP package
- AEC & AQG324 Qualified and PPAP Capable
- 1200 V – 35 A 3-Phase IGBT Inverter with Integral Gate Drivers and Protection
- Low-Loss, Short-Circuit Rated IGBTs
- Very Low Thermal Resistance using Al₂O₃ DBC Substrate
- Built-In Bootstrap Diodes and Dedicated Vs Pins Simplify PCB Layout
- Separate Open-Emitter Pins from Low-Side IGBTs for Three-Phase Current Sensing
- Single-Grounded Power Supply Supported
- Built-In NTC Thermistor for Temperature Monitoring and Management
- Adjustable Over-Current Protection via Integrated Sense-IGBTs
- Isolation Rating of 2500 Vrms/1 min
- This is a Pb-Free Device

Applications

- Automotive High Voltage Auxiliary Motors
 - ◆ Climate e-Compressors
 - ◆ Oil/Water Pumps
 - ◆ Super/Turbo Chargers
 - ◆ Variety Fans
- Motion Control
 - ◆ Industrial Motor

Related Resources

- [AN-9075](#) – Users Guide for 1200V SPM[®] 2 Series
- [AN-9076](#) – Mounting Guide for New SPM[®] 2 Package

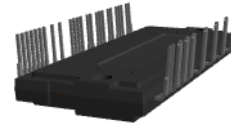

3D Package Drawing
(Click to Activate 3D Content)

DIP34 80x33, AUTOMOTIVE MODULE
CASE MODGL

MARKING DIAGRAM

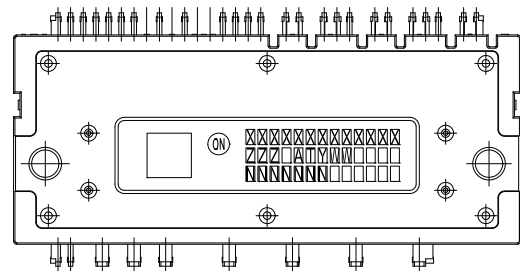

XXXXXXXXXXXX = Specific Device Code
 ZZZ = Lot ID
 AT = Assembly & Test Location
 Y = Year
 W = Work Week
 NNN = Serial Number

ORDERING INFORMATION

See detailed ordering and shipping information on page 6 of this data sheet.

NFVA23512NP2T

- [AN-9079](#) – Thermal Performance of 1200V Motion SPM[®] 2 Series by Mounting Torque

Integrated Power Functions

- 1200 V–35 A IGBT inverter for three–phase DC/AC power conversion (Refer to Figure 1)

Integrated Drive, Protection and System Control Functions

- For inverter high–side IGBTs: gate drive circuit, high–voltage isolated high–speed level shifting control circuit, Under–Voltage Lock–Out Protection (UVLO)

- For inverter low–side IGBTs: gate drive circuit, Short–Circuit Protection (SCP) control supply circuit, Under–Voltage Lock–Out Protection (UVLO)
- Fault signaling: corresponding to UVLO (low–side supply) and SC faults
- Input interface: active–high interface, works with 3.3/5 V logic, schmitt–trigger input

PIN CONFIGURATION

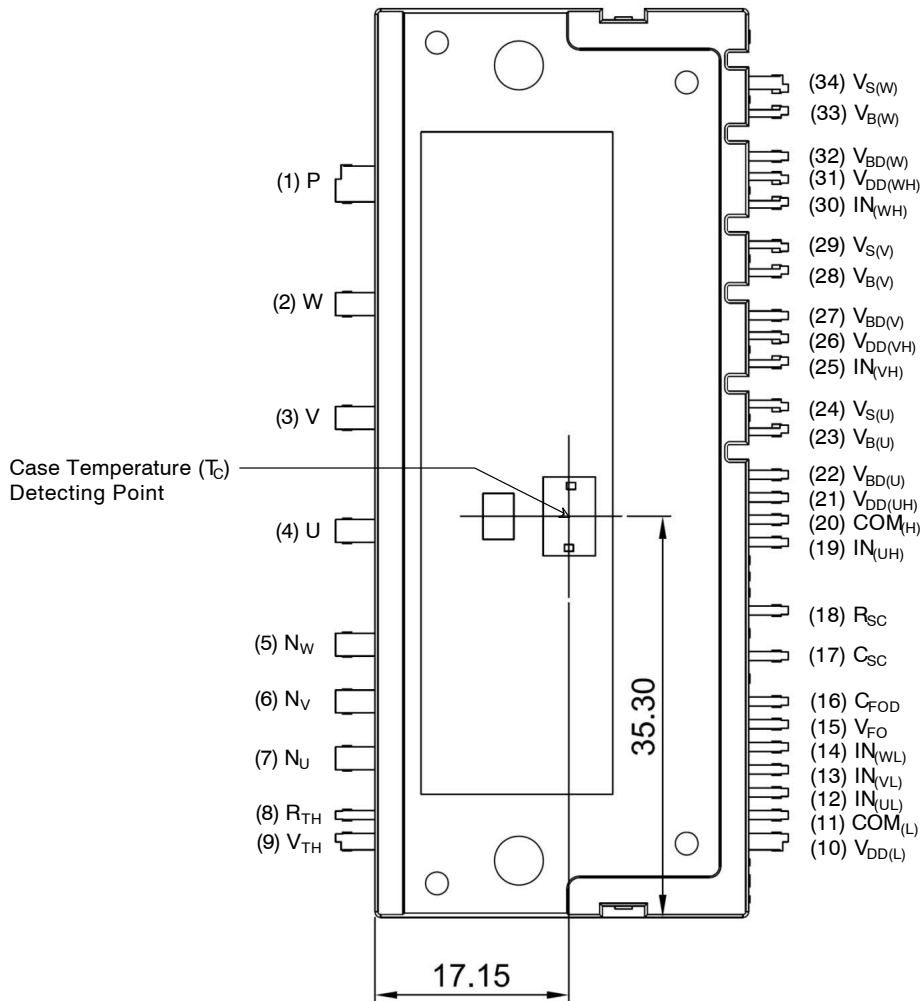

Figure 1. Top View

NFVA23512NP2T

PIN DESCRIPTIONS

Pin Number	Pin Name	Pin Description
1	P	Positive DC-Link Input
2	W	Output for W Phase
3	V	Output for V Phase
4	U	Output for U Phase
5	N _W	Negative DC-Link Input for W Phase
6	N _V	Negative DC-Link Input for V Phase
7	N _U	Negative DC-Link Input for U Phase
8	R _{TH}	Series Resistor for Thermistor (Temperature Detection)
9	V _{TH}	Thermistor Bias Voltage
10	V _{DD(L)}	Low-Side Bias Voltage for IC and IGBTs Driving
11	COM _(L)	Low-Side Common Supply Ground
12	IN _(UL)	Signal Input for Low-Side U Phase
13	IN _(VL)	Signal Input for Low-Side V Phase
14	IN _(WL)	Signal Input for Low-Side W Phase
15	V _{FO}	Fault Output
16	C _{FOD}	Capacitor for Fault Output Duration Selection
17	C _{SC}	Shut Down Input for Short-Circuit Current Detection Input
18	R _{SC}	Resistor for Short-Circuit Current Detection
19	IN _(UH)	Signal Input for High-Side U Phase
20	COM _(H)	High-Side Common Supply Ground
21	V _{DD(UH)}	High-Side Bias Voltage for U Phase IC
22	V _{BD(U)}	Anode of Bootstrap Diode for U Phase High-Side Bootstrap Circuit
23	V _{B(U)}	High-Side Bias Voltage for U Phase IGBT Driving
24	V _{S(U)}	High-Side Bias Voltage Ground for U Phase IGBT Driving
25	IN _(VH)	Signal Input for High-Side V Phase
26	V _{DD(VH)}	High-Side Bias Voltage for V Phase IC
27	V _{BD(V)}	Anode of Bootstrap Diode for V Phase High-Side Bootstrap Circuit
28	V _{B(V)}	High-Side Bias Voltage for V Phase IGBT Driving
29	V _{S(V)}	High-Side Bias Voltage Ground for V Phase IGBT Driving
30	IN _(WH)	Signal Input for High-Side W Phase
31	V _{DD(WH)}	High-Side Bias Voltage for W Phase IC
32	V _{BD(W)}	Anode of Bootstrap Diode for W Phase High-Side Bootstrap Circuit
33	V _{B(W)}	High-Side Bias Voltage for W Phase IGBT Driving
34	V _{S(W)}	High-Side Bias Voltage Ground for W Phase IGBT Driving

NFVA23512NP2T

INTERNAL EQUIVALENT CIRCUIT AND INPUT/OUTPUT PINS

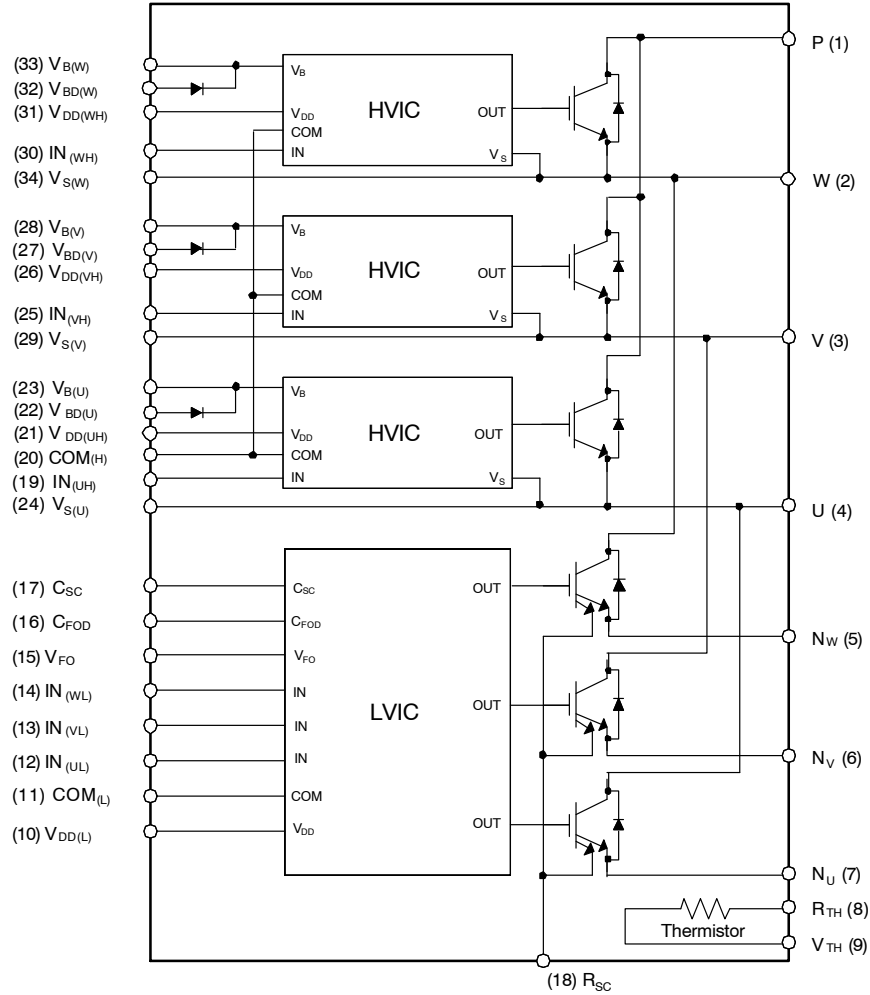

NOTES:

1. Inverter low-side is composed of three IGBTs, freewheeling diodes for each IGBT, and one control IC. It has gate drive and protection functions.
2. Inverter power side is composed of four inverter DC-link input terminals and three inverter output terminals.
3. Inverter high-side is composed of three IGBTs, freewheeling diodes, and three drive ICs for each IGBT.

Figure 2. Internal Block Diagram

NFVA23512NP2T

ABSOLUTE MAXIMUM RATINGS ($T_J = 25^\circ\text{C}$ unless otherwise noted)

Symbol	Parameter	Conditions	Rating	Unit
INVERTER PART				
V_{PN}	Supply Voltage	Applied between P- N_U , N_V , N_W	900	V
$V_{PN(\text{Surge})}$	Supply Voltage (Surge)	Applied between P- N_U , N_V , N_W	1000	V
V_{CES}	Collector-Emitter Voltage		1200	V
$\pm I_C$	Each IGBT Collector Current	$T_C = 100^\circ\text{C}$, $T_J \leq 150^\circ\text{C}$, $V_{DD} \geq 15\text{ V}$	35	A
$\pm I_{CP}$	Each IGBT Collector Current (Peak)	$T_C = 25^\circ\text{C}$, $T_J \leq 150^\circ\text{C}$, Under 1 ms Pulse Width	70	A
P_C	Collector Dissipation	$T_C = 25^\circ\text{C}$ per One Chip	171	W
T_J	Operating Junction Temperature	$V_{CES} = 960\text{ V}$	-40-150	$^\circ\text{C}$
		$V_{CES} = 1200\text{ V}$	-40-125	

CONTROL PART

V_{DD}	Control Supply Voltage	Applied between $V_{DD(H)}$, $V_{DD(L)}$ - COM	20	V
V_{BS}	High-Side Control Bias Voltage	Applied between $V_{B(U)}$ - $V_{S(U)}$, $V_{B(V)}$ - $V_{S(V)}$, $V_{B(W)}$ - $V_{S(W)}$	20	V
V_{IN}	Input Signal Voltage	Applied between $IN_{(UH)}$, $IN_{(VH)}$, $IN_{(WH)}$, $IN_{(UL)}$, $IN_{(VL)}$, $IN_{(WL)}$ - COM	-0.3- $V_{DD}+0.3$	V
V_{FO}	Fault Output Supply Voltage	Applied between V_{FO} - COM	-0.3- $V_{DD}+0.3$	V
I_{FO}	Fault Output Current	Sink Current at V_{FO} pin	2	mA
V_{SC}	Current Sensing Input Voltage	Applied between C_{SC} - COM	-0.3- $V_{DD}+0.3$	V

BOOTSTRAP DIODE PART

V_{RRM}	Maximum Repetitive Reverse Voltage		1200	V
I_F	Forward Current	$T_C = 25^\circ\text{C}$, $T_J \leq 150^\circ\text{C}$	1.0	A
I_{FP}	Forward Current (Peak)	$T_C = 25^\circ\text{C}$, $T_J \leq 150^\circ\text{C}$, Under 1 ms Pulse Width	2.0	A
T_J	Operating Junction Temperature		-40-150	$^\circ\text{C}$

TOTAL SYSTEM

t_{SC}	Short Circuit Withstand Time	$V_{DD} = V_{BS} \leq 16.5\text{ V}$, $V_{PN} \leq 800\text{ V}$, $T_J = 150^\circ\text{C}$ Non-repetitive	3	μs
T_{STG}	Storage Temperature		-40-150	$^\circ\text{C}$
V_{ISO}	Isolation Voltage	60 Hz, Sinusoidal, AC 1 minute, Connection Pins to Heat Sink Plate	2500	V_{rms}

Stresses exceeding those listed in the Maximum Ratings table may damage the device. If any of these limits are exceeded, device functionality should not be assumed, damage may occur and reliability may be affected.

THERMAL RESISTANCE

Symbol	Parameter	Conditions	Min.	Typ.	Max.	Unit
$R_{th(j-c)Q}$	Junction to Case Thermal Resistance (Note 4)	Inverter IGBT part (per 1/6 module)	-	-	0.73	$^\circ\text{C/W}$
$R_{th(j-c)F}$		Inverter FWD part (per 1/6 module)	-	-	1.26	$^\circ\text{C/W}$
L_σ	Package Stray Inductance	P to N_U , N_V , N_W (Note 5)	-	32	-	nH

- For the measurement point of case temperature (T_C), please refer to Figure 1. DBC discoloration and Picker Circle Printing allowed, please refer to application note [AN-9190](#) (Impact of DBC Oxidation on SPM[®] Module Performance).
- Stray inductance per phase measured per IEC 60747-15.

NFVA23512NP2T

ELECTRICAL CHARACTERISTICS – INVERTER PART (T_J as specified)

Symbol	Parameter	Conditions	Min.	Typ.	Max.	Unit	
$V_{CE(SAT)}$	Collector – Emitter Saturation Voltage	$V_{DD} = V_{BS} = 15\text{ V}$, $V_{IN} = 5\text{ V}$, $I_C = 35\text{ A}$, $T_J = 25^\circ\text{C}$	–	1.90	2.50	V	
		$V_{DD} = V_{BS} = 15\text{ V}$, $V_{IN} = 5\text{ V}$, $I_C = 35\text{ A}$, $T_J = 150^\circ\text{C}$		2.35	2.95	V	
V_F	FWDi Forward Voltage	$V_{IN} = 0\text{ V}$, $I_F = 35\text{ A}$, $T_J = 25^\circ\text{C}$	–	2.10	2.70	V	
		$V_{IN} = 0\text{ V}$, $I_F = 35\text{ A}$, $T_J = 150^\circ\text{C}$		2.05	2.65	V	
HS	t_{ON}	High Side Switching Times $V_{PN} = 600\text{ V}$, $V_{DD} = 15\text{ V}$, $I_C = 35\text{ A}$, $T_J = 25^\circ\text{C}$ $V_{IN} = 0\text{ V} \Leftrightarrow 5\text{ V}$, Inductive Load See Figure 4 (Note 6)	0.70	1.20	1.80	μs	
			$t_{C(ON)}$	–	0.40	0.85	μs
			t_{OFF}	–	1.20	1.80	μs
			$t_{C(OFF)}$	–	0.15	0.55	μs
			t_{rr}	–	0.20	–	μs
LS	t_{ON}	Low Side Switching Times $V_{PN} = 600\text{ V}$, $V_{DD} = 15\text{ V}$, $I_C = 35\text{ A}$, $T_J = 25^\circ\text{C}$ $V_{IN} = 0\text{ V} \Leftrightarrow 5\text{ V}$, Inductive Load See Figure 4 (Note 6)	0.50	1.00	1.60	μs	
			$t_{C(ON)}$	–	0.40	0.85	μs
			t_{OFF}	–	1.40	2.00	μs
			$t_{C(OFF)}$	–	0.20	0.60	μs
			t_{rr}	–	0.25	–	μs
I_{CES}	Collector–Emitter Leakage Current	$T_J = 25^\circ\text{C}$, $V_{CE} = V_{CES}$	–	–	3	mA	

Product parametric performance is indicated in the Electrical Characteristics for the listed test conditions, unless otherwise noted. Product performance may not be indicated by the Electrical Characteristics if operated under different conditions.

6. t_{ON} and t_{OFF} include the propagation delay time of the internal drive IC. $t_{C(ON)}$ and $t_{C(OFF)}$ are the switching time of IGBT itself under the given gate driving condition internally. For the detailed information see Figure 3.

PACKAGE MARKING AND ORDERING INFORMATION

Device	Device Marking	Package	Shipping
NFVA23512NP2T	NFVA23512NP2T	ASPM34-CAA (Pb-Free)	6 Units/Tube

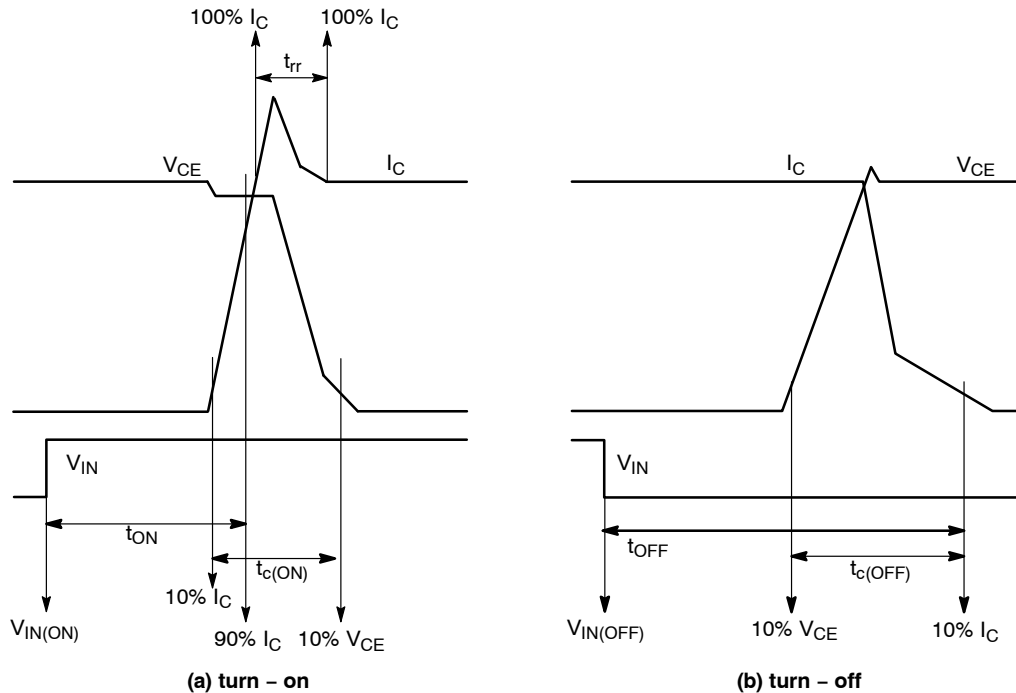

Figure 3. Switching Time Definition

NFVA23512NP2T

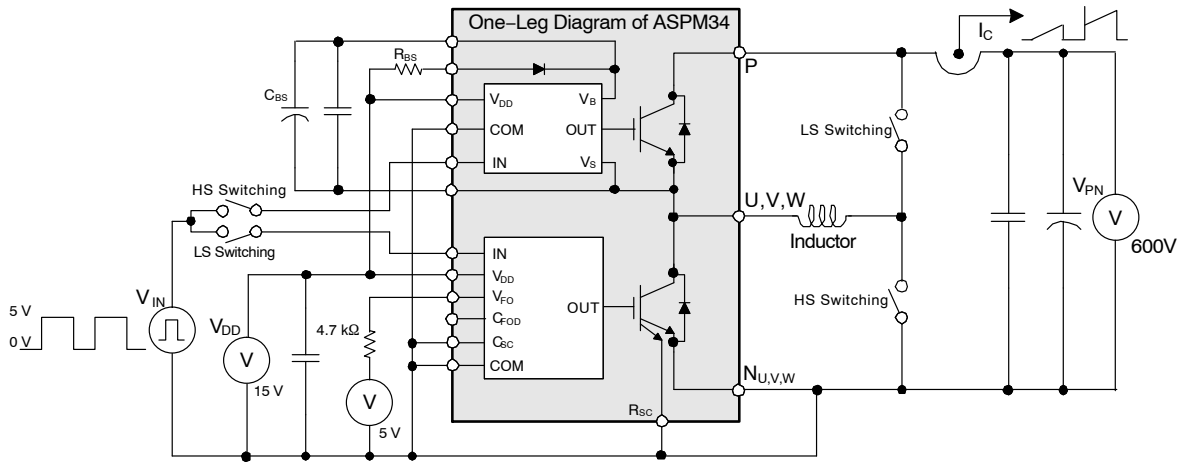

Figure 4. Example Circuit for Switching Test

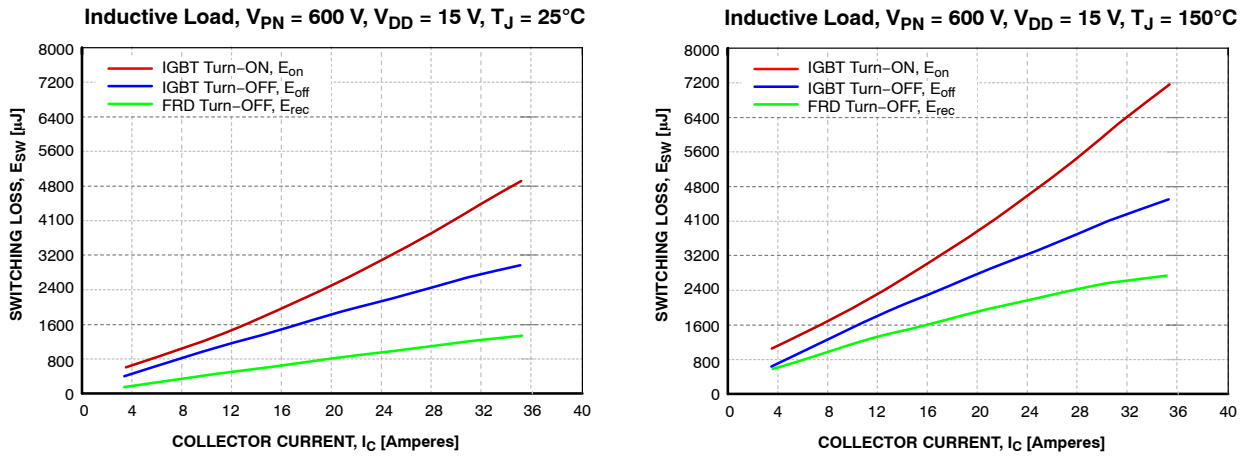

Figure 5. Switching Loss Characteristics

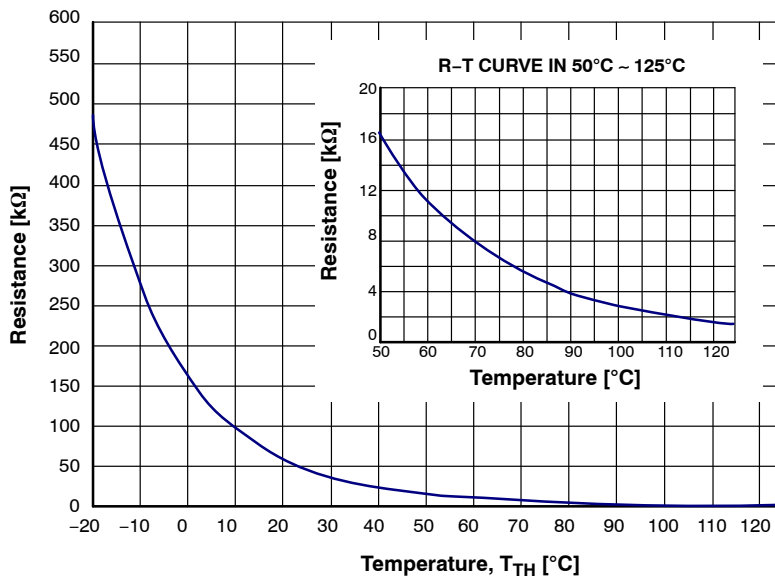

Figure 6. R-T Curve of Built-in Thermistor

NFVA23512NP2T

BOOTSTRAP DIODE PART (T_J as specified)

Symbol	Parameter	Conditions	Min.	Typ.	Max.	Unit
V _F	Forward Voltage	I _F = 1.0 A, T _J = 25°C	-	2.2	-	V
t _{rr}	Reverse-Recovery Time	I _F = 1.0 A, dI _F /dt = 50 A/μs, T _J = 25°C	-	80	-	ns

CONTROL PART (T_J = 25°C)

Symbol	Parameter	Conditions	Min.	Typ.	Max.	Unit	
I _{QDDH}	Quiescent V _{DD} Supply Current	V _{DD(H)} = 15 V, I _{N(UH,VH,WH)} = 0 V		-	0.15	mA	
I _{QDDL}		V _{DD(L)} = 15 V, I _{N(UL,VL,WL)} = 0 V	V _{DD(UH) - COM(H), V_{DD(VH) - COM(H), V_{DD(WH) - COM(H)}}}		-	4.80	mA
I _{PDDH}	Operating V _{DD} Supply Current	V _{DD(H)} = 15 V, f _{PWM} = 20 kHz, duty = 50%, applied to one PWM signal input for High-Side	V _{DD(UH) - COM(H), V_{DD(VH) - COM(H), V_{DD(WH) - COM(H)}}}	-	-	0.30	mA
I _{PDDL}		V _{DD(L)} = 15 V, f _{PWM} = 20 kHz, duty = 50%, applied to one PWM signal input for Low-Side	V _{DD(L) - COM(L)}	-	-	15.5	mA
I _{QBS}	Quiescent V _{BS} Supply Current	V _{BS} = 15 V, I _{N(UH,VH,WH)} = 0 V	V _{B(U) - V_{S(U), V_{B(V) - V_{S(V), V_{B(W) - V_{S(W)}}}}}}	-	-	0.30	mA
I _{PBS}	Operating V _{BS} Supply Current	V _{DD} = V _{BS} = 15 V, f _{PWM} = 20 kHz, duty = 50%, applied to one PWM signal input for High-Side	V _{B(U) - V_{S(U), V_{B(V) - V_{S(V), V_{B(W) - V_{S(W)}}}}}}	-	-	12.0	mA
V _{FOH}	Fault Output Voltage	V _{DD} = 15 V, V _{SC} = 0 V, V _{FO} Circuit: 4.7 kΩ to 5 V Pull-up		4.5	-	-	V
V _{FOL}		V _{DD} = 15 V, V _{SC} = 1 V, V _{FO} Circuit: 4.7 kΩ to 5 V Pull-up		-	-	0.50	V
I _{SEN}	Sensing Current of Each Sense IGBT	V _{DD} = 15 V, V _{IN} = 5 V, R _{SC} = 0 Ω, No Connection of Shunt Resistor at N _{U,V,W} terminal	I _C = 35 A	-	36.0	-	mA
V _{SC(ref)}	Short Circuit Trip Level	V _{DD} = 15 V (Note 7)	C _{SC} - COM(L)	0.43	0.50	0.57	V
I _{SC}	Short Circuit Current Level for Trip	R _{SC} = 16 Ω (±1%), No Connection of Shunt Resistor at N _{U,V,W} Terminal (Note 7)		-	70	-	A
UV _{DDD}	Supply Circuit Under-Voltage Protection	Detection Level		10.3	-	12.8	V
UV _{DDR}		Reset Level		10.8	-	13.3	V
UV _{BSD}		Detection Level		9.5	-	12.0	V
UV _{BSR}		Reset Level		10.0	-	12.5	V
t _{FOD}	Fault-Out Pulse Width	C _{FOD} = Open	(Note 8)	50	-	-	μs
		C _{FOD} = 2.2 nF		1.7	-	-	ms
V _{IN(ON)}	ON Threshold Voltage	Applied between I _{N(UH,VH,WH)} - COM(H)		-	-	2.6	V
V _{IN(OFF)}	OFF Threshold Voltage	I _{N(UL,VL,WL)} - COM(L)		0.8	-	-	V
R _{TH}	Resistance of Thermistor	at T _{TH} = 25°C	See Figure 6 (Note 9)	-	47	-	kΩ
		at T _{TH} = 100°C		-	2.9	-	kΩ

7. Short-circuit current protection functions only at the low-sides because the sense current is divided from main current at low-side IGBTs. Inserting the shunt resistor for monitoring the phase current at N_U, N_V, N_W terminal, the trip level of the short-circuit current is changed.

8. The fault-out pulse width t_{FOD} depends on the capacitance value of C_{FOD} according to the following approximate equation :

$$t_{FOD} = 0.8 \times 10^6 \times C_{FOD}$$

9. T_{TH} is the temperature of thermistor itself. To know case temperature (T_C), conduct experiments considering the application.

NFVA23512NP2T

RECOMMENDED OPERATING CONDITIONS

Symbol	Parameter	Conditions	Value			Unit
			Min.	Typ.	Max.	
V_{PN}	Supply Voltage	Applied between P – N_U , N_V , N_W	300	600	800	V
V_{DD}	Control Supply Voltage	Applied between $V_{DD(UH, VH, WH)} - COM_{(H)}$, $V_{DD(L)} - COM_{(L)}$	14.0	15	16.5	V
V_{BS}	High-Side Bias Voltage	Applied between $V_{B(U)} - V_{S(U)}$, $V_{B(V)} - V_{S(V)}$, $V_{B(W)} - V_{S(W)}$	13.0	15	18.5	V
dV_{DD}/dt , dV_{BS}/dt	Control Supply Variation		-1	-	1	V/ μ s
t_{dead}	Blanking Time for Preventing Arm-Short	For Each Input Signal	2.0	-	-	μ s
f_{PWM}	PWM Input Signal	$-40^{\circ}C \leq T_C \leq 125^{\circ}C$, $-40^{\circ}C \leq T_J \leq 150^{\circ}C$	-	-	20	kHz
V_{SEN}	Voltage for Current Sensing	Applied between N_U , N_V , $N_W - COM_{(H, L)}$ (Including Surge Voltage)	-5	-	5	V
$PW_{IN(ON)}$	Minimum Input Pulse Width	$V_{DD} = V_{BS} = 15$ V, $I_C \leq 70$ A, Wiring Inductance between $N_{U,V,W}$ and DC Link N < 10 nH (Note 10)	2.0	-	-	μ s
$PW_{IN(OFF)}$			2.0	-	-	
T_J	Junction Temperature		-40	-	150	$^{\circ}C$

Functional operation above the stresses listed in the Recommended Operating Ranges is not implied. Extended exposure to stresses beyond the Recommended Operating Ranges limits may affect device reliability.

10. This product might not make response if input pulse width is less than the recommended value.

MECHANICAL CHARACTERISTICS AND RATINGS

Parameter	Conditions	Value			Unit	
		Min.	Typ.	Max.		
Device Flatness	See Figure 7	0	-	+200	μ m	
Mounting Torque	Mounting Screw: M4 See Figure 8	Recommended 1.0 N•m	0.9	1.0	1.5	N•m
		Recommended 10.1 kg•cm	9.1	10.1	15.1	kg•cm
Terminal Pulling Strength	Load 19.6 N	10	-	-	s	
Terminal Bending Strength	Load 9.8 N, 90 degrees Bend	2	-	-	times	
Weight		-	50	-	g	

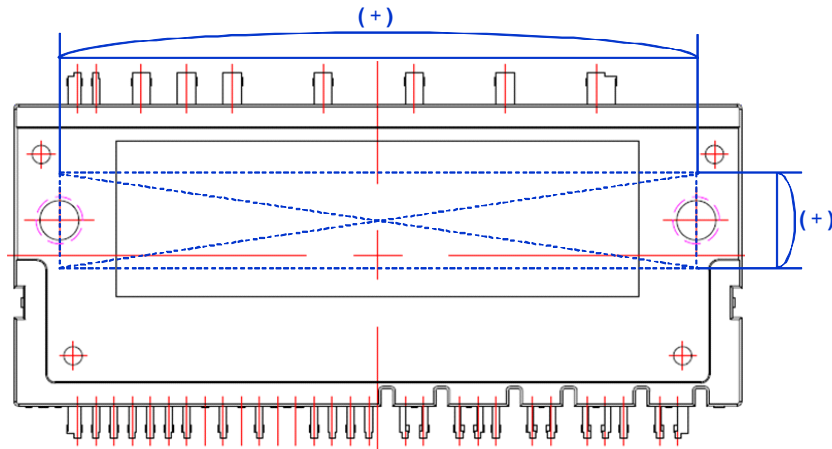
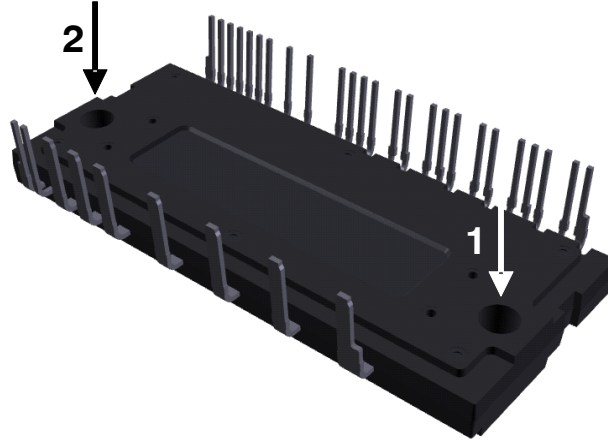

Figure 7. Flatness Measurement Position

NFVA23512NP2T



NOTES:

11. Do not make over torque when mounting screws. Much mounting torque may cause DBC cracks, as well as bolts and Al heat-sink destruction.
12. Avoid one-sided tightening stress. Figure 8 shows the recommended torque order for mounting screws. Uneven mounting can cause the DBC substrate of package to be damaged. The pre-screwing torque is set to 20–30% of maximum torque rating.

Figure 8. Mounting Screws Torque Order

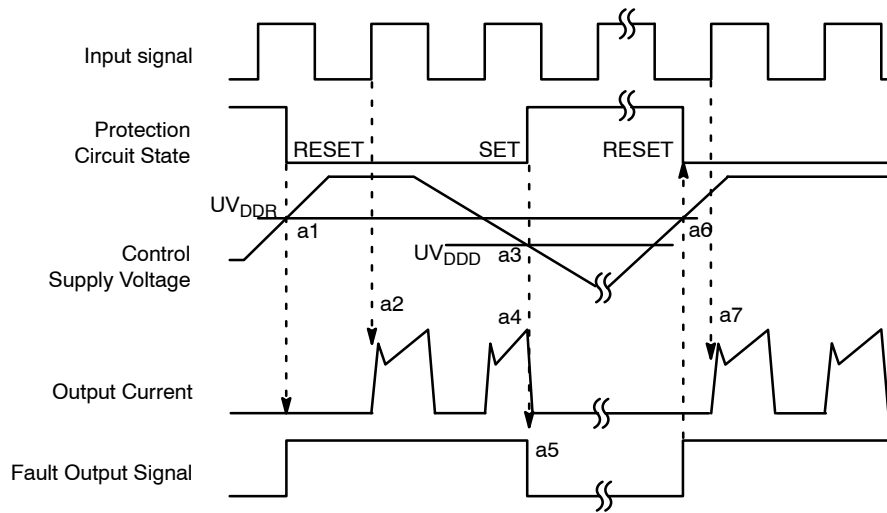

- a1: Control supply voltage rises: After the voltage rises UV_{DDR} , the circuits start to operate when next input is applied.
- a2: Normal operation: IGBT ON and carrying current.
- a3: Under voltage detection (UV_{DDD}).
- a4: IGBT OFF in spite of control input condition.
- a5: Fault output operation starts with a fixed pulse width according to the condition of the external capacitor C_{FOD} .
- a6: Under voltage reset (UV_{DDR}).
- a7: Normal operation: IGBT ON and carrying current by triggering next signal from LOW to HIGH.

Figure 9. Under-Voltage Protection (Low-Side)

NFVA23512NP2T

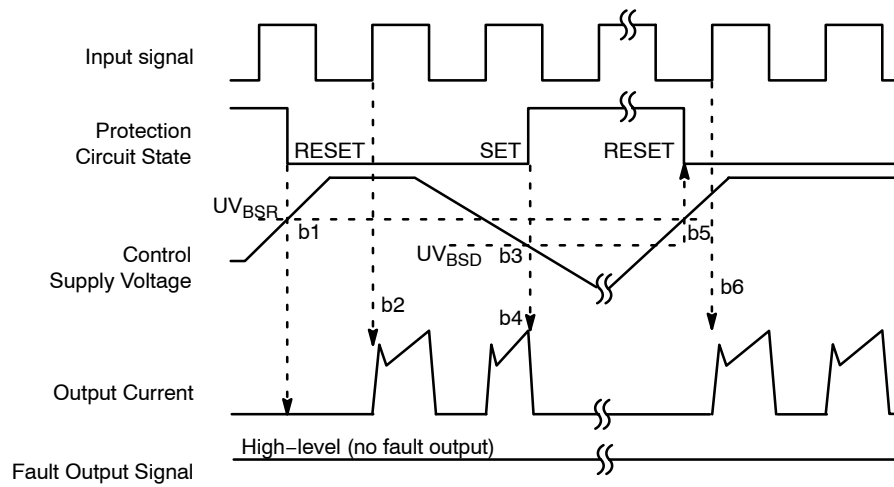

- b1: Control supply voltage rises: After the voltage rises UV_{BSR} , the circuits start to operate when next input is applied.
- b2: Normal operation: IGBT ON and carrying current.
- b3: Under voltage detection (UV_{BSD}).
- b4: IGBT OFF in spite of control input condition, but there is no fault output signal.
- b5: Under-voltage reset (UV_{BSR}).
- b6: Normal operation: IGBT ON and carrying current by triggering next signal from LOW to HIGH.

Figure 10. Under-Voltage Protection (High-Side)

NFVA23512NP2T

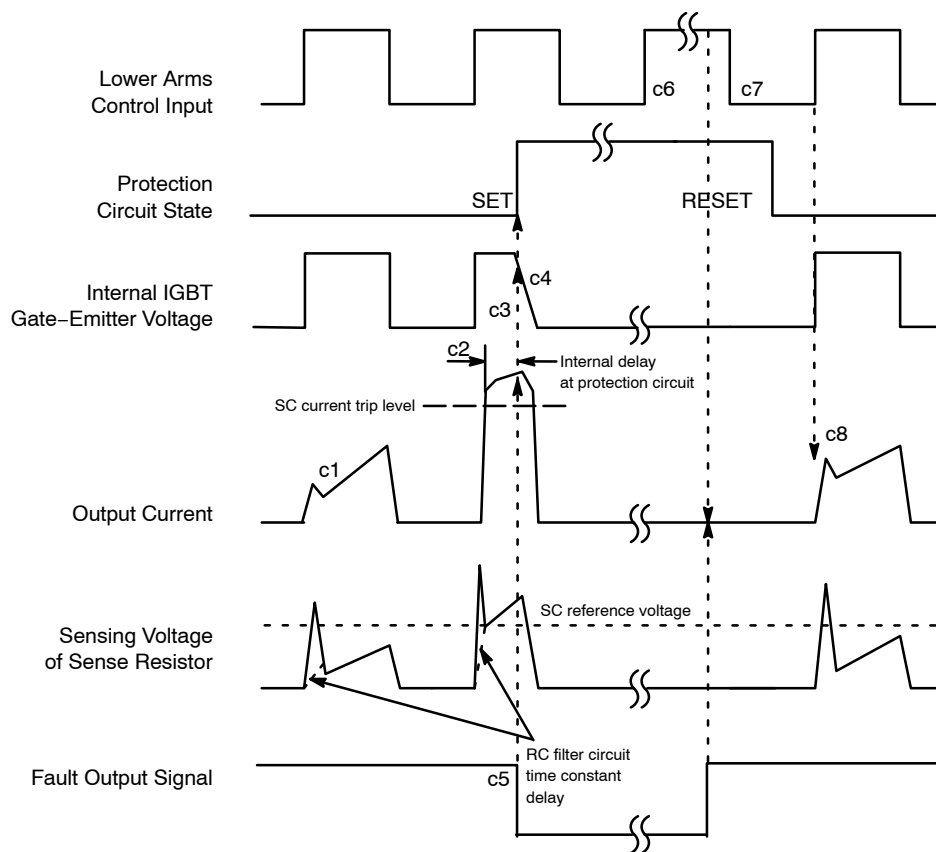

(with the external sense resistance and RC filter connection)

c1: Normal operation: IGBT ON and carrying current.

c2: Short-circuit current detection (SC trigger).

c3: All low-side IGBT's gate are hard interrupted.

c4: All low-side IGBTs turn OFF.

c5: Fault output operation starts with a fixed pulse width according to the condition of the external capacitor C_{FOD} .

c6: Input HIGH: IGBT ON state, but during the active period of fault output the IGBT doesn't turn ON.

c7: Fault output operation finishes, but IGBT doesn't turn on until triggering next signal from LOW to HIGH.

c8: Normal operation: IGBT ON and carrying current.

Figure 11. Short-Circuit Current Protection (Low-Side Operation Only)

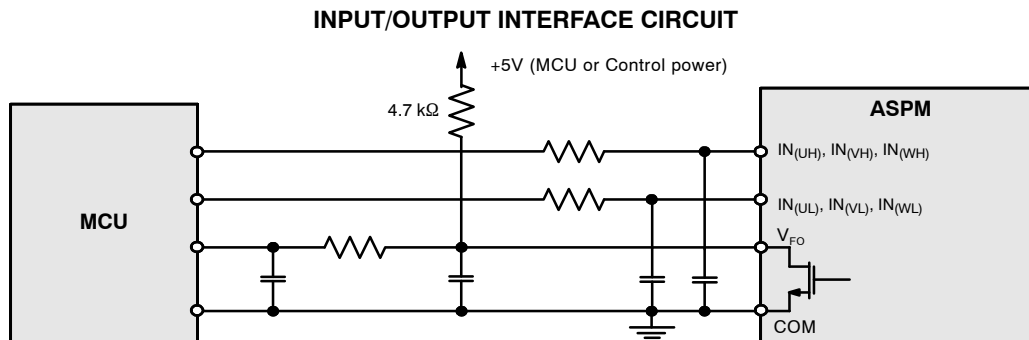

NOTE:

13. RC coupling at each input might change depending on the PWM control scheme used in the application and the wiring impedance of the application's printed circuit board. The input signal section of the Motion SPM 2 product integrates 5 kΩ (typ.) pull-down resistor. Therefore, when using an external filtering resistor, please pay attention to the signal voltage drop at input terminal.

Figure 12. Recommended CPU I/O Interface Circuit

NFVA23512NP2T

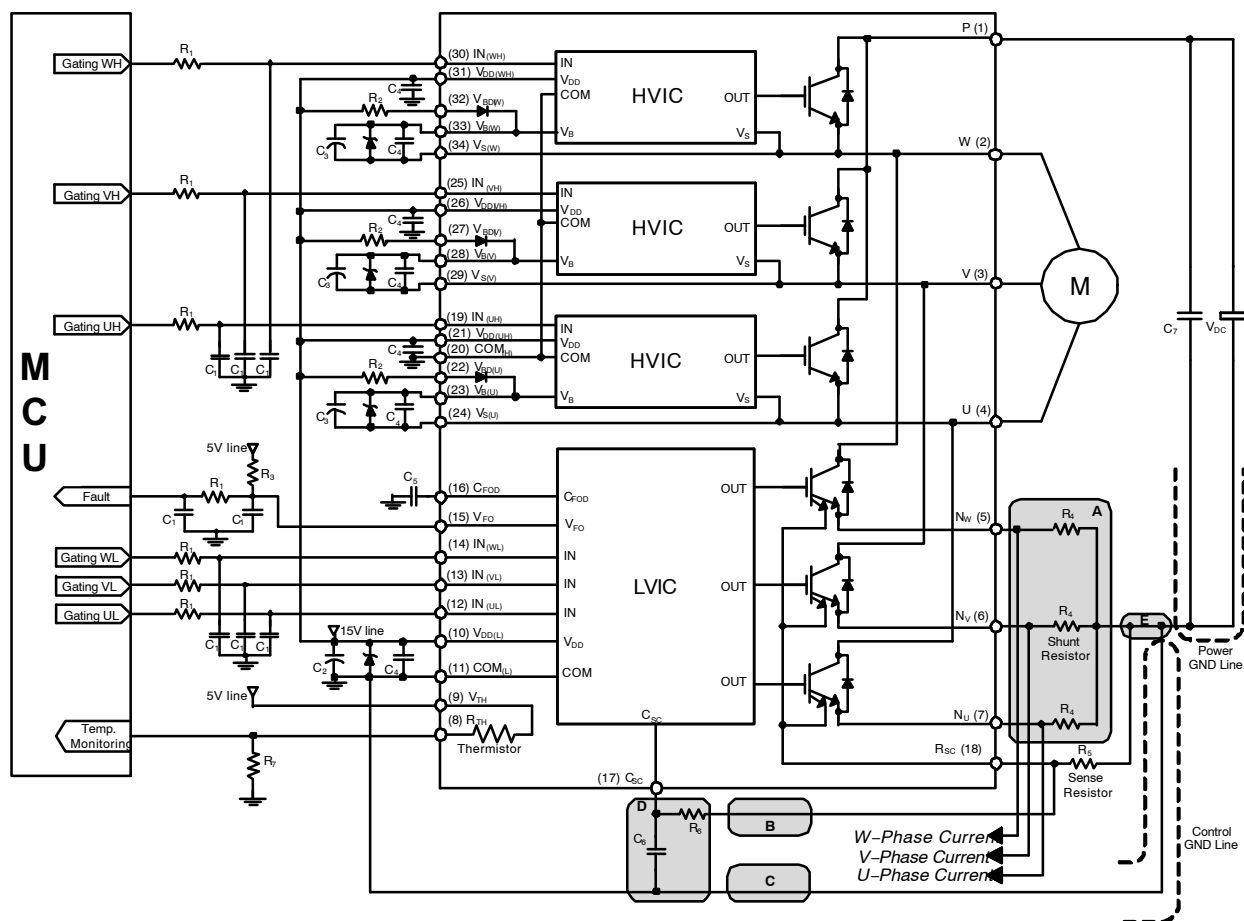

NOTES:

14. To avoid malfunction, the wiring of each input should be as short as possible. (less than 2 – 3 cm)
15. V_{FO} output is open-drain type. The signal line should be pulled up to the positive side of the MCU or control power supply with a resistor that makes I_{FO} up to 2 mA. Refer to Figure 13.
16. Fault out pulse width can be adjust by capacitor C_5 connected to the C_{FOD} terminal.
17. Input signal is active-HIGH type. There is a 5 k Ω resistor inside the IC to pull-down each input signal line to GND. RC coupling circuits should be adopted for the prevention of input signal oscillation. R_1C_1 time constant should be selected in the range 50–150 ns. (Recommended $R_1 = 100 \Omega$, $C_1 = 1$ nF)
18. Each wiring pattern inductance of A point should be minimized (Recommended less than 10 nH). Use the shunt resistor R_4 of surface mounted (SMD) type to reduce wiring inductance. To prevent malfunction, wiring of point E should be connected to the terminal of the shunt resistor R_4 as close as possible.
19. To insert the shunt resistor to measure each phase current at N_U , N_V , N_W terminal, it makes to change the trip level I_{SC} about the short-circuit current.
20. To prevent errors of the protection function, the wiring of B, C and D point should be as short as possible. The wiring of B between C_{SC} filter and R_{SC} terminal should be divided at the point that is close to the terminal of sense resistor R_5 .
21. For stable protection function, use the sense resistor R_5 with resistance variation within 1% and low inductance value.
22. In the short-circuit protection circuit, please select the R_6C_6 time constant in the range 1.0–1.5 μ s. R_6 should be selected with minimum of 10 times larger resistance than sense resistor R_5 . Do enough evaluation on the real system because short-circuit protection time may vary wiring pattern layout and value of the R_6C_6 time constant.
23. Each capacitor should be mounted as close to the pins of the ASPM34 product as possible.
24. To prevent surge destruction, the wiring between the smoothing capacitor C_7 and the P & GND pins should be as short as possible. The use of a high-frequency non-inductive capacitor between the P & GND pins is recommended.
25. Relays are used at almost every systems of electrical equipment at industrial application. In these cases, there should be sufficient distance between the MCU and the relays.
26. The Zener diode or transient voltage suppressor should be adopted for the protection of ICs from the surge destruction between each pair of control supply terminals (Recommended Zener diode is 22 V/1 W, which has the lower Zener impedance characteristic than about 15 Ω).
27. C_2 of around seven times larger than bootstrap capacitor C_3 is recommended.
28. Choose the electrolytic capacitor with good temperature characteristic in C_3 . Choose 0.1–0.2 μ F R-category ceramic capacitors with good temperature and frequency characteristics in C_4 .

Figure 13. Typical Application Circuit

SPM is a registered trademark of Semiconductor Components Industries, LLC dba "onsemi" or its affiliates and/or subsidiaries in the United States and/or other countries.

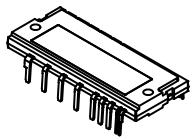

**DIP34 80x33, AUTOMOTIVE MODULE
CASE MODGL
ISSUE O**

DATE 19 OCT 2018

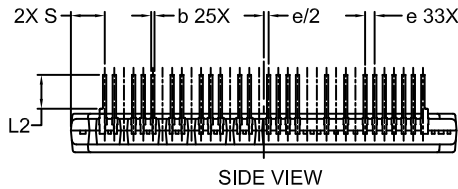

SIDE VIEW

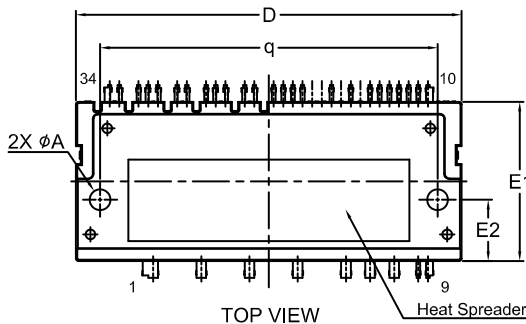

TOP VIEW

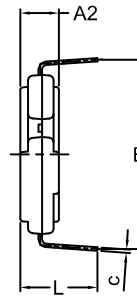

END VIEW

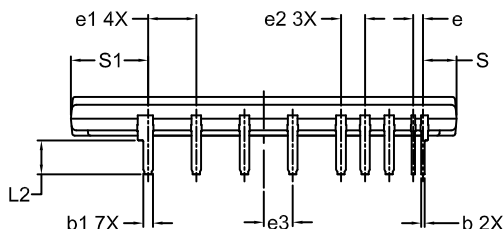

SIDE VIEW

NOTES:

1. DIMENSIONING AND TOLERANCING PER, ASME Y14.5M, 2009.
2. CONTROLLING DIMENSION: MILLIMETERS
3. DIMENSIONS ARE EXCLUSIVE OF BURRS, MOLD FLASH AND TIE BAR EXTRUSIONS.

DIM	MILLIMETERS		
	MIN.	NOM.	MAX.
A2	7.90	8.00	8.10
b	0.60	0.70	0.80
b1	1.90	2.00	2.10
c	0.65	0.70	0.80
D	79.70	80.00	80.30
E	38.76	39.26	39.76
E1	32.70	33.00	33.30
E2	12.50	12.70	12.90
e	1.70	2.00	2.30
e1	9.70	10.00	10.30
e2	4.70	5.00	5.30
e3	5.70	6.00	6.30
L	15.50	16.00	16.50
L2	6.70	7.00	7.30
q	69.75	70.00	70.25
S	7.00 REF		
S1	16.00 REF		
φA	4.10	4.30	4.50

**GENERIC
MARKING DIAGRAM***

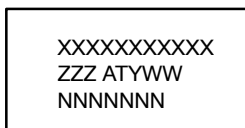

- XXXX = Specific Device Code
- ZZZ = Lot ID
- AT = Assembly & Test Location
- Y = Year
- W = Work Week
- NNN = Serial Number

*This information is generic. Please refer to device data sheet for actual part marking. Pb-Free indicator, "G" or microdot "μ", may or may not be present. Some products may not follow the Generic Marking.

DOCUMENT NUMBER:	98AON97156G	Electronic versions are uncontrolled except when accessed directly from the Document Repository. Printed versions are uncontrolled except when stamped "CONTROLLED COPY" in red.
DESCRIPTION:	DIP34 80x33, AUTOMOTIVE MODULE	PAGE 1 OF 1

onsemi and Onsemi are trademarks of Semiconductor Components Industries, LLC dba onsemi or its subsidiaries in the United States and/or other countries. onsemi reserves the right to make changes without further notice to any products herein. onsemi makes no warranty, representation or guarantee regarding the suitability of its products for any particular purpose, nor does onsemi assume any liability arising out of the application or use of any product or circuit, and specifically disclaims any and all liability, including without limitation special, consequential or incidental damages. onsemi does not convey any license under its patent rights nor the rights of others.

onsemi, **Onsemi**, and other names, marks, and brands are registered and/or common law trademarks of Semiconductor Components Industries, LLC dba "**onsemi**" or its affiliates and/or subsidiaries in the United States and/or other countries. **onsemi** owns the rights to a number of patents, trademarks, copyrights, trade secrets, and other intellectual property. A listing of **onsemi**'s product/patent coverage may be accessed at www.onsemi.com/site/pdf/Patent-Marking.pdf. **onsemi** reserves the right to make changes at any time to any products or information herein, without notice. The information herein is provided "as-is" and **onsemi** makes no warranty, representation or guarantee regarding the accuracy of the information, product features, availability, functionality, or suitability of its products for any particular purpose, nor does **onsemi** assume any liability arising out of the application or use of any product or circuit, and specifically disclaims any and all liability, including without limitation special, consequential or incidental damages. Buyer is responsible for its products and applications using **onsemi** products, including compliance with all laws, regulations and safety requirements or standards, regardless of any support or applications information provided by **onsemi**. "Typical" parameters which may be provided in **onsemi** data sheets and/or specifications can and do vary in different applications and actual performance may vary over time. All operating parameters, including "Typicals" must be validated for each customer application by customer's technical experts. **onsemi** does not convey any license under any of its intellectual property rights nor the rights of others. **onsemi** products are not designed, intended, or authorized for use as a critical component in life support systems or any FDA Class 3 medical devices or medical devices with a same or similar classification in a foreign jurisdiction or any devices intended for implantation in the human body. Should Buyer purchase or use **onsemi** products for any such unintended or unauthorized application, Buyer shall indemnify and hold **onsemi** and its officers, employees, subsidiaries, affiliates, and distributors harmless against all claims, costs, damages, and expenses, and reasonable attorney fees arising out of, directly or indirectly, any claim of personal injury or death associated with such unintended or unauthorized use, even if such claim alleges that **onsemi** was negligent regarding the design or manufacture of the part. **onsemi** is an Equal Opportunity/Affirmative Action Employer. This literature is subject to all applicable copyright laws and is not for resale in any manner.

ADDITIONAL INFORMATION

TECHNICAL PUBLICATIONS:

Technical Library: www.onsemi.com/design/resources/technical-documentation
onsemi Website: www.onsemi.com

ONLINE SUPPORT: www.onsemi.com/support

For additional information, please contact your local Sales Representative at www.onsemi.com/support/sales