

General Description

The SRE100N120FSUDA is a Field Stop Trench IGBT with anti-parallel diode, which offers low switching losses, high energy efficiency and high avalanche ruggedness for soft switching applications such as UPS, solar inverters, etc.

The SRE100N120FSUDA is TO-247Plus package.

Features

- High Breakdown Voltage to 1200V
- Advanced Trench Fieldstop technology
 - Low $V_{CE(sat)}$
 - High Ruggedness, Temperature Stability
 - Easy Parallel Switching Capability due to Positive Temperature Coefficient in $V_{CE(sat)}$
- High Speed Switching
- Enhanced Avalanche Capability
- Non-Automotive Qualified

Application

- Solar Inverters
- Uninterrupted Power Supply
- Industrial Power Supplies
- Grid Inverter

Ordering Information

SRE100N120FSUDA□□-□

Circuit Type		G: Green
Package		Blank: Tube
TP:TO-247Plus		TR: Tape & Reel

Symbol

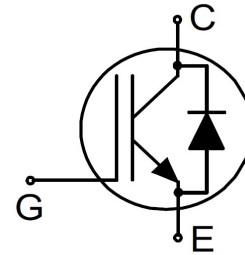
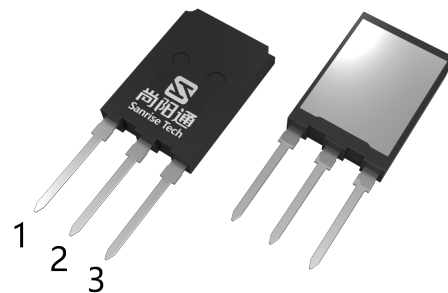

Figure 1 Symbol of SRE100N120FSUDA

Package Type



TO-247Plus

- Pin 1- Gate
- Pin 2&backside- Collector
- Pin 3-Emitter

Figure 2 Package Type of SRE100N120FSUDA

Package	Part Number	Marking ID	Packing Type
	Green	Green	
TO-247Plus	SRE100N120FSUDATP-G7	SRE100N120FSUDATPG7	Tube

Absolute Maximum Ratings

Parameter	Symbol	Rating	Unit
Collector-emitter voltage	V_{CES}	1200	V
Gate-emitter Voltage	V_{GES}	± 20	V
Transient Gate-emitter Voltage		± 30	V
Continuous Collector Current	I_C	$T_C=25^\circ\text{C}$	160 ⁽¹⁾
		$T_C=100^\circ\text{C}$	100
Pulsed Collector Current, Limited by T_{Jmax}		I_{CM}	400
Diode Continuous Collector Current	I_F	$T_C=25^\circ\text{C}$	120
		$T_C=100^\circ\text{C}$	100 ⁽²⁾
Diode Pulsed Current, Limited by T_{Jmax}		I_{FM}	320
Power dissipation	P_{tot}	$T_C=25^\circ\text{C}$	880
		$T_C=100^\circ\text{C}$	440
Operating Junction Temperature		T_J	$-40\sim 175^{(3)}$
Storage Temperature		T_{STG}	$-55 \sim 150$
Lead Temperature (Soldering, 10 sec)		T_{LEAD}	260

Note:

1. Limited to bond wire.
2. Current level is limited by T_{j_max} .
3. Reliability testing conducted at $T_j=175^\circ\text{C}$.

Thermal Resistance

Parameter	Package	Symbol	Min	Typ	Max	Unit
IGBT thermal Resistance, Junction-to-Case	TO-247Plus	R_{thJC}	-	-	0.17	°C/W
Diode thermal Resistance, Junction-to-Case	TO-247Plus	R_{thJC}	-	-	0.4	
Thermal Resistance, Junction-to-Ambient	TO-247Plus	R_{thJA}	-	-	40	

Electrical Characteristics
 $T_J = 25^\circ\text{C}$, unless otherwise specified.

Parameter	Symbol	Test Conditions	Min	Typ	Max	Unit	
Statistic Characteristics							
Collector-emitter Breakdown Voltage	BV_{CES}	$V_{GE}=0V, I_C=500\mu A$	1200			V	
Gate Threshold Voltage	$V_{GE(th)}$	$V_{CE}=V_{GE}, I_C=1.6mA$	4.6	5.6	6.6	V	
Collector-emitter saturation voltage	V_{CEsat}	$V_{GE}=15V, I_C=100A,$ $T_J=25^\circ\text{C}$		1.8	2.2	V	
		$T_J=125^\circ\text{C}$		2.46		V	
		$T_J=175^\circ\text{C}$		2.86		V	
Zero Gate Voltage Collector Current	I_{CES}	$V_{CE}=1200V, V_{GE}=0V$ $T_J=25^\circ\text{C}$			100	μA	
		$T_J=175^\circ\text{C}$			1.3	mA	
Gate-emitter Leakage Current	Forward	I_{GESF}	$V_{GE}=20V, V_{CE}=0V$			100	nA
	Reverse	I_{GESR}	$V_{GE}=-20V, V_{CE}=0V$			-100	nA
Dynamic Characteristics							
Input Capacitance	C_{IES}	$V_{CE}=25V, V_{GE}=0V,$ $f=100KHz$		6965		pF	
Output Capacitance	C_{OES}			399			
Reverse Transfer Capacitance	C_{RES}			70			
Gate Resistance	R_G	$f=1MHz, \text{Open Drain}$		0.83		Ω	
Turn-on Delay Time	$t_{d(on)}$	$T_J=25^\circ\text{C},$ $V_{CC}=600V,$ $I_C=100A$ $R_G=10\Omega, V_{GE}=0/15V$ (Ets includes tail current and FRD reverse recovery energy.)		55		ns	
Rise Time	t_r			66		ns	
Turn-off Delay Time	$t_{d(off)}$			276		ns	
Fall Time	t_f			100		ns	
Turn-on energy	E_{on}			7		mJ	
Turn-off energy	E_{off}			2.6		mJ	
Total switching energy	E_{ts}			9.6		mJ	
Turn-on Delay Time	$t_{d(on)}$		$T_J=150^\circ\text{C}$ $V_{CC}=600V,$ $I_C=100A; R_G=10\Omega,$ $V_{GE}=0/15V$ (Ets includes tail current and FRD reverse recovery energy.)		47		ns
Rise Time	t_r				66		ns
Turn-off Delay Time	$t_{d(off)}$				288		ns
Fall Time	t_f			111		ns	
Turn-on energy	E_{on}			8.2		mJ	
Turn-off energy	E_{off}			3.4		mJ	
Total switching energy	E_{ts}			11.6		mJ	
Gate to Emitter Charge	Q_{GE}	$V_{CC}=600V, I_C=100A$ $V_{GE}=0 \text{ to } 15V$			46		nC
Gate to Collector Charge	Q_{GC}				97		
Gate Charge Total	Q_G			168			

100A 1200V Trench Fieldstop IGBT with FRD
SRE100N120FSUDA

Parameter	Symbol	Test Conditions	Min	Typ	Max	Unit
Reverse Diode Characteristics						
Drain-Source Diode Forward Voltage	V_F	$V_{GE}=0V, I_F=100A$ $T_j=25^\circ C$		2.5	2.9	V
		$V_{GE}=0V, I_F=100A$ $T_j=125^\circ C$		2.45		
		$V_{GE}=0V, I_F=100A$ $T_j=175^\circ C$		2.26		
Reverse Recovery Time	t_{rr}	$T_j=25^\circ C$		316		ns
Reverse Recovery Charge	Q_{rr}			2.0		μC
Peak Reverse Recovery Current	I_{rrm}	$V_R=600V, I_F=100A$ $dI_F/dt=1200A/\mu s$		31		A
Diode peak rate of fall of reverse Recovery current during t_b	di_{rr}/dt			-485		A/ μs
Reverse Recovery Time	t_{rr}	$T_j=150^\circ C$ $V_R=600V, I_F=100A$ $dI_F/dt=1200A/\mu s$		468		ns
Reverse Recovery Charge	Q_{rr}			6.7		μC
Peak Reverse Recovery Current	I_{rrm}			59		A
Diode peak rate of fall of reverse Recovery current during t_b	di_{rr}/dt			-435		A/ μs

Typical Performance Characteristics

<p>Figure 3: IGBT FBSOA</p>  <p>$I_C = f(V_{CE}); V_{GE} \geq 15/0V; T_j \leq 175\text{ }^\circ\text{C}$</p>	<p>Figure 4: IGBT Transient Thermal Impedance</p>  <p>$R_{th(j-c)} = f(t_p); \text{ parameter: } D = t_p/T$</p>
<p>Figure 5: Power Dissipation</p>  <p>$P_{tot} = f(T_c)$</p>	<p>Figure 6: Collector Current vs. Temperature</p>  <p>$I_C = f(T_j); V_{GE} \geq 15V; T_j \leq 175\text{ }^\circ\text{C}$</p>

Figure 7: Typ. Output Characteristics



 $I_C = f(V_{CE}); T_j = 25^\circ\text{C}; \text{parameter: } V_{GE}$

Figure 8: Typ. Output Characteristics

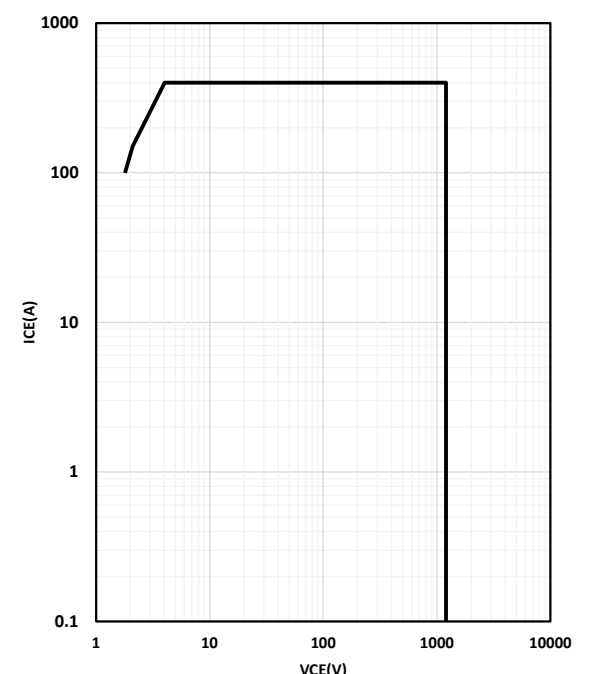
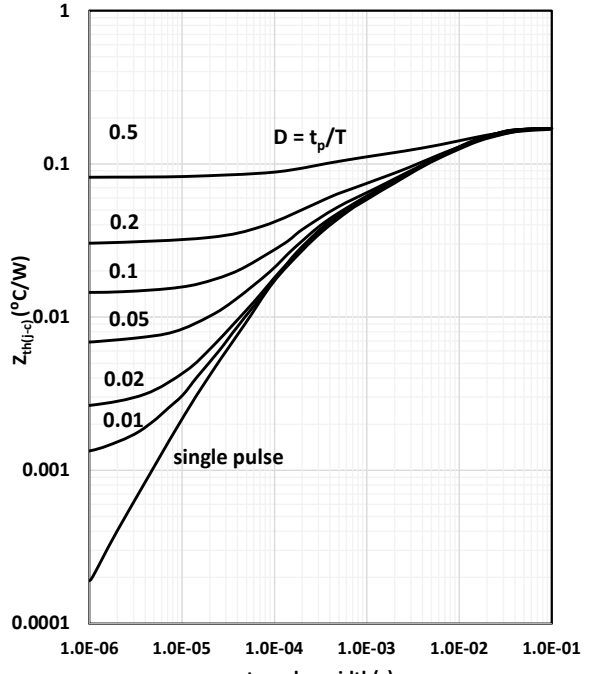
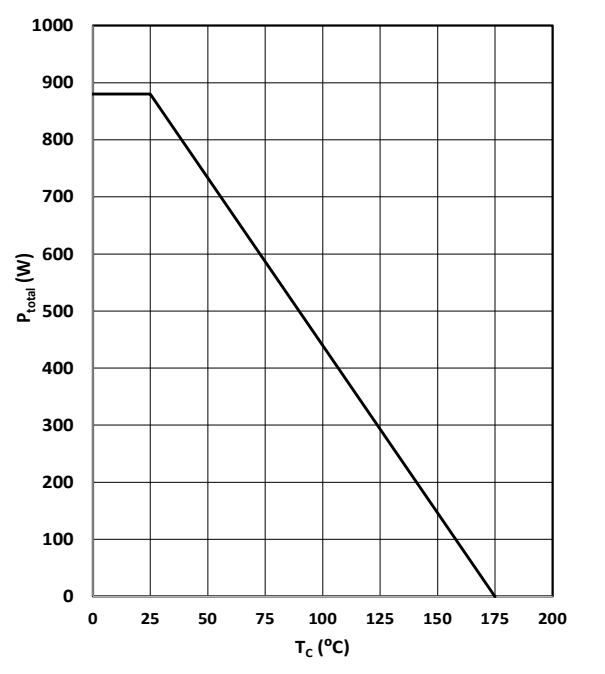
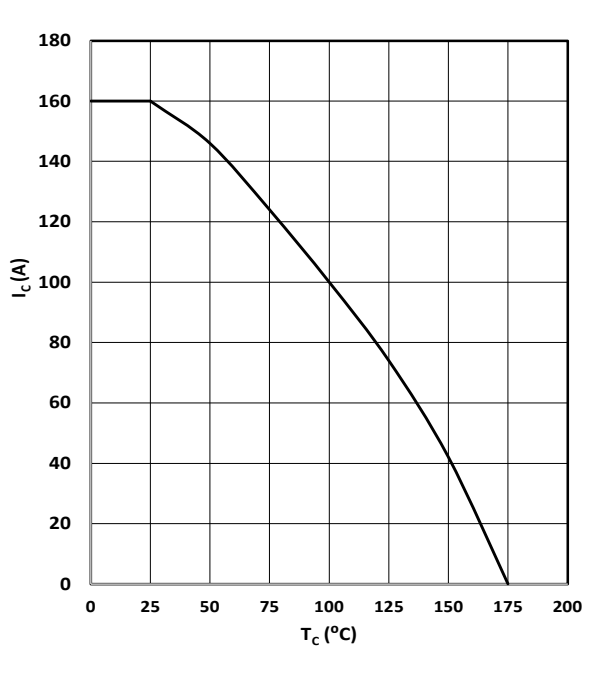

 $I_C = f(V_{CE}); T_j = 175^\circ\text{C}; \text{parameter: } V_{GE}$

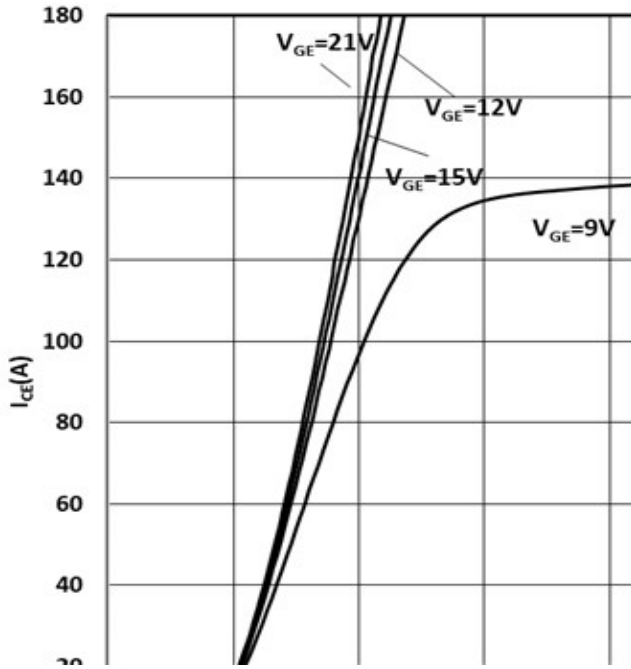
Figure 9: Typ. Transfer Characteristics

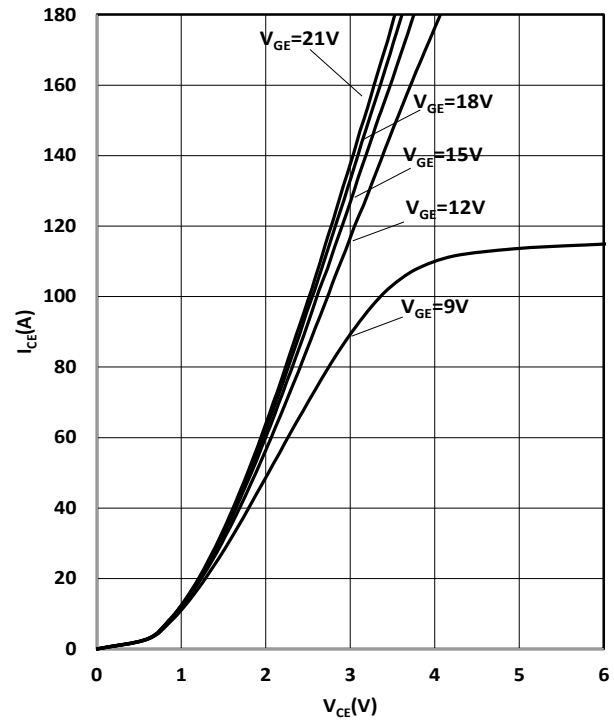

 $I_C = f(V_{GE}); V_{CE} = 20\text{V}$

Figure 10: Typ. Collector Voltage vs. Temperature

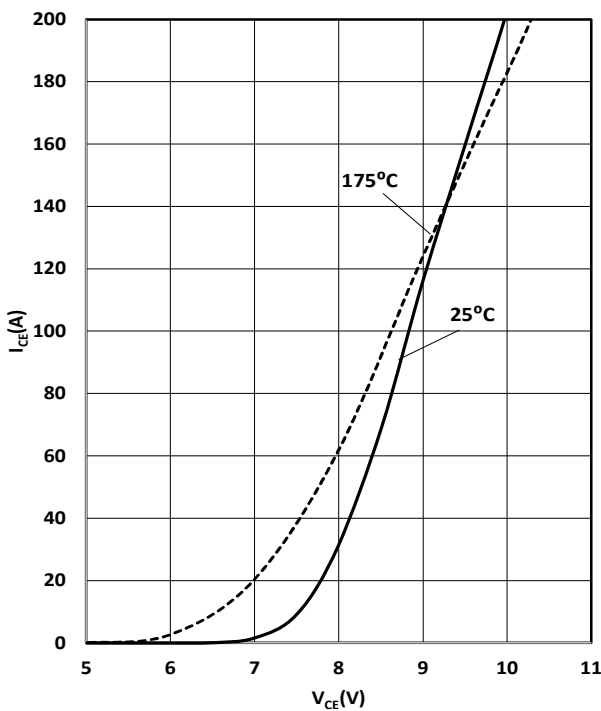

 $V_{CE} = f(T_j); V_{GE} = 15\text{V}$

Figure 11: IGBT switching energy losses

$$E=f(I_C) ; V_{CE}=600V; T_j=25^{\circ}C; R_G=10\Omega$$

Figure 12: IGBT switching energy losses

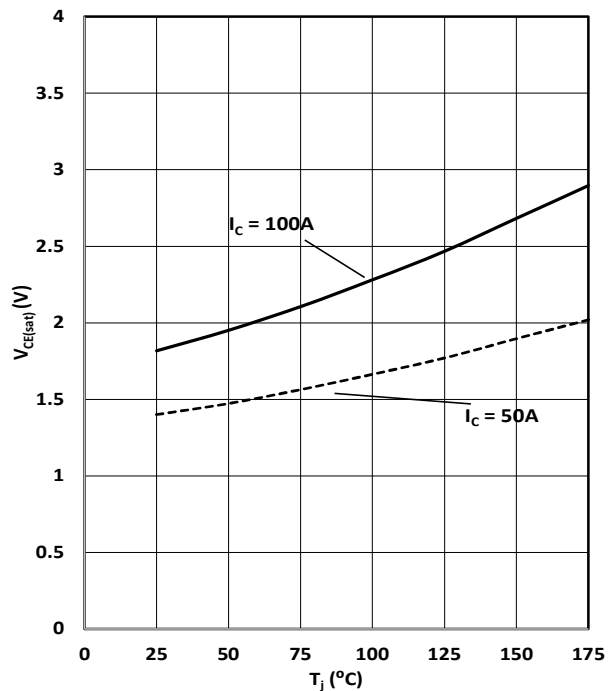
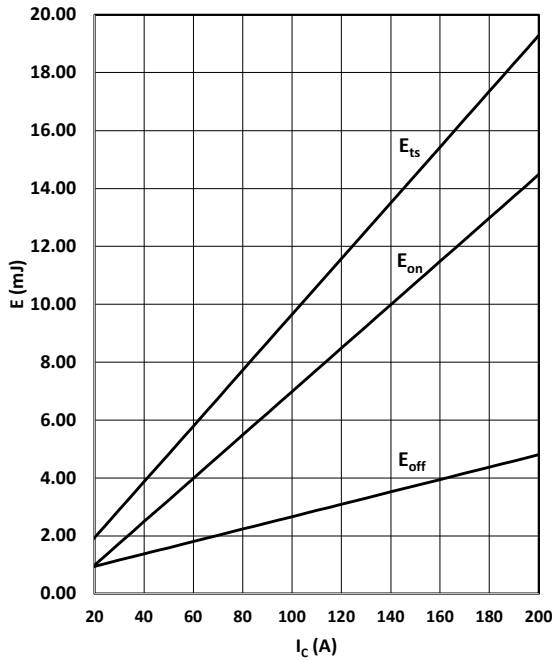
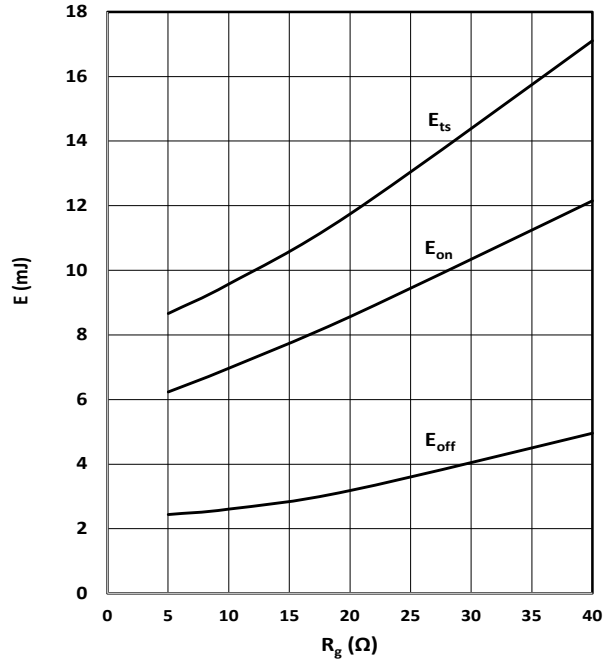
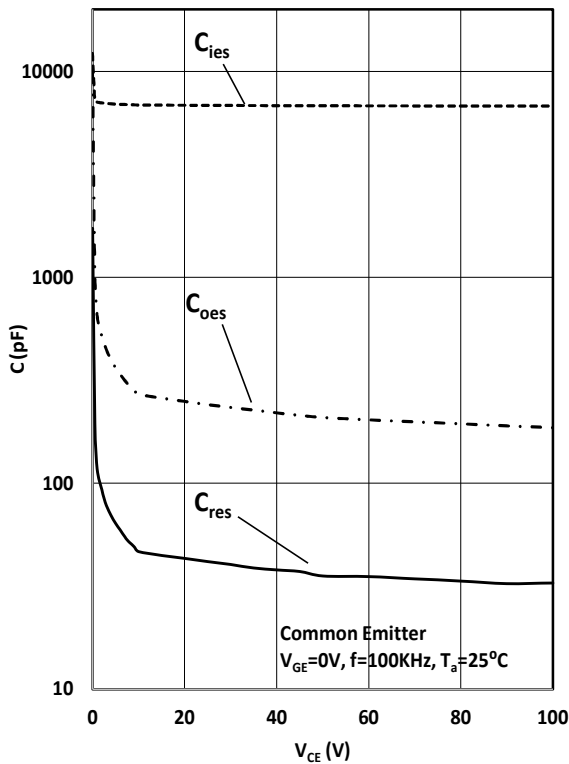
$$E=f(R_G) ; V_{CE}=600V; T_j=25^{\circ}C; I_C=100A$$

Figure 13: Typ. Capacitances

$$C=f(V_{CE}); V_{GE}=0; f=100KHz$$

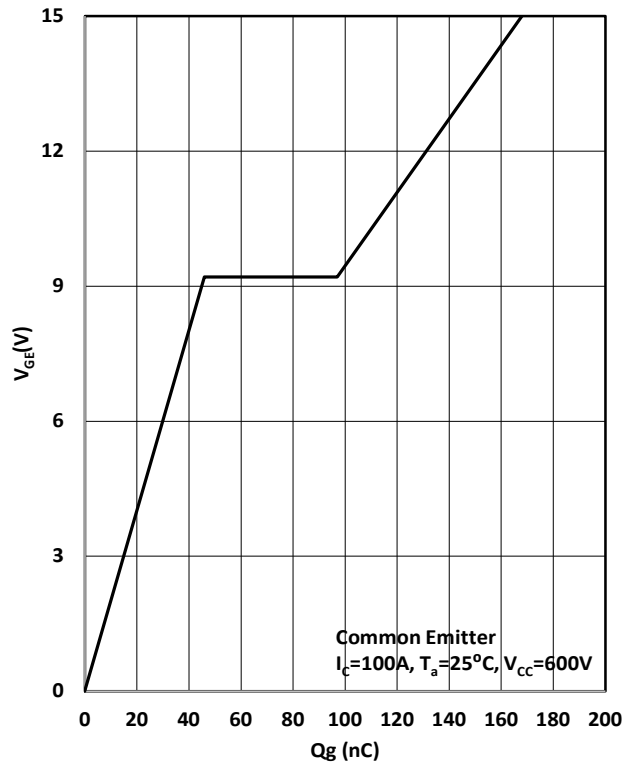
Figure 14: Typ. Gate Charge

$$V_{GE}=f(Q_g), I_C=100A$$

Figure 15: Typ. Switching time as a function of gate resistance



 $V_{CE}=600V; I_C=100A; T_j=25^{\circ}C$

Figure 16: Typ. Switching time as a function of junction temperature

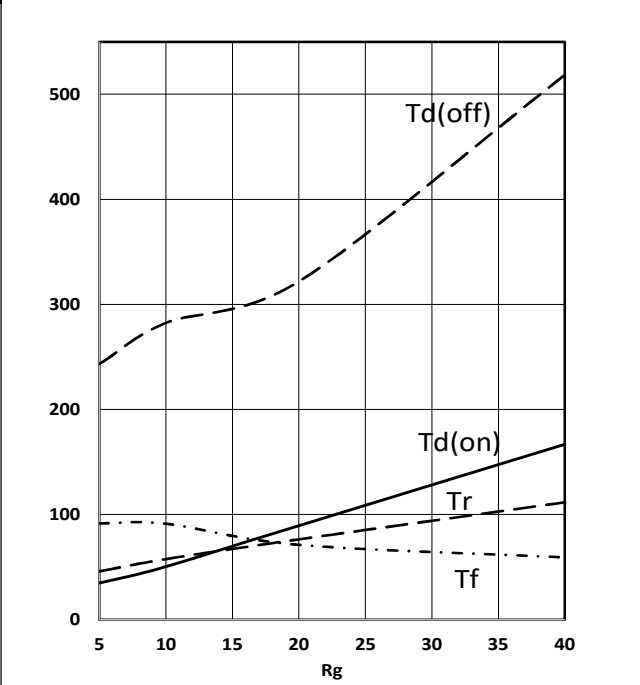

 $V_{CE}=600V; I_C=100A; R_G=10\Omega$

Figure 17: Typical switching energy losses as a function of junction temperature

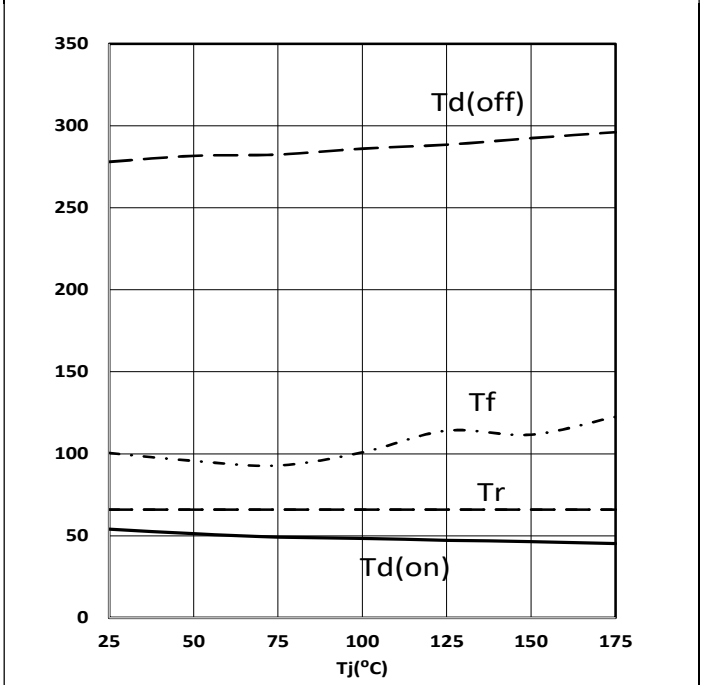

 $E=f(T_j); V_{CE}=600V; I_C=50A; R_G=10\Omega$

Figure 18: Typical switching energy losses as a function of junction temperature

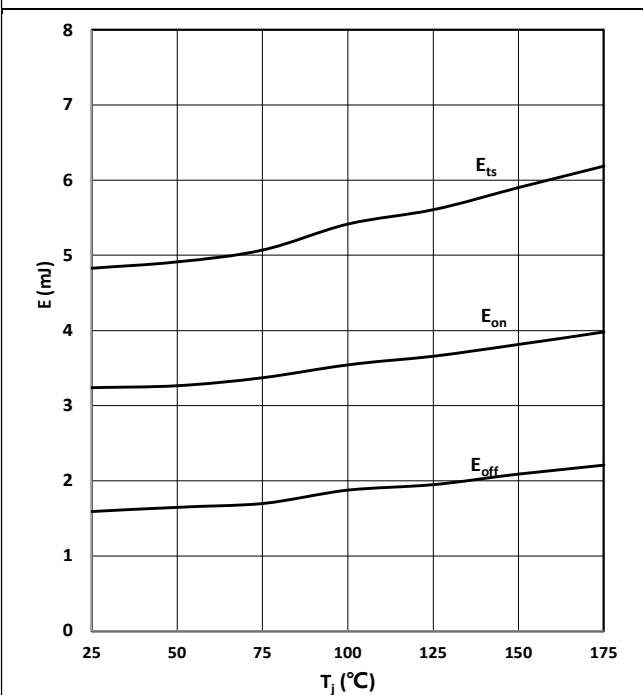

 $E=f(T_j); V_{CE}=600V; I_C=100A; R_G=10\Omega$

Figure 19: Typ. diode forward current as a function of forward voltage

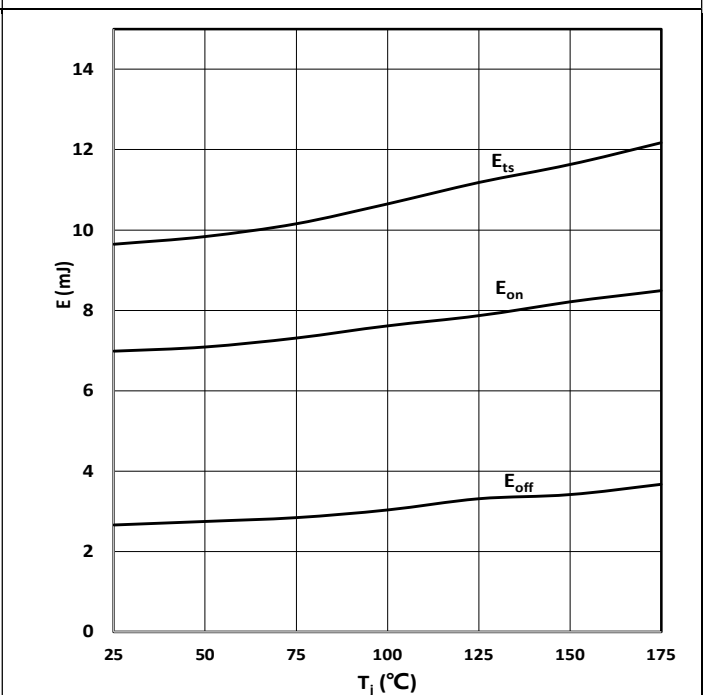
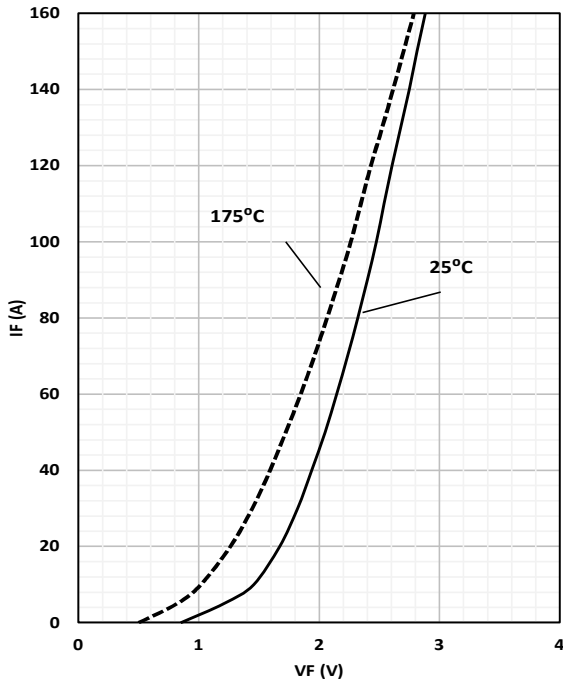
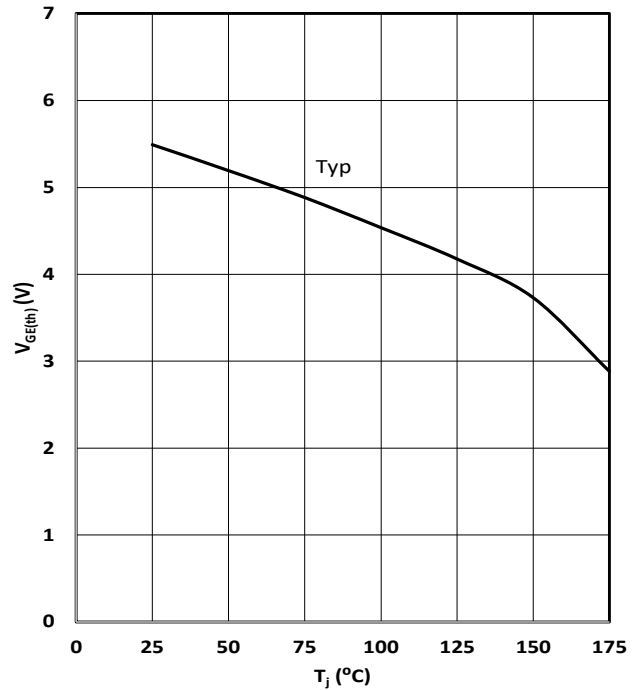

$$I_F = f(V_F);$$

Figure 20: Typ. emitter threshold voltage as a function of junction temperature



$$V_{GE} = f(T_j); I_{CE} = 1.6\text{mA}$$

Figure 21: IGBT switching energy losses

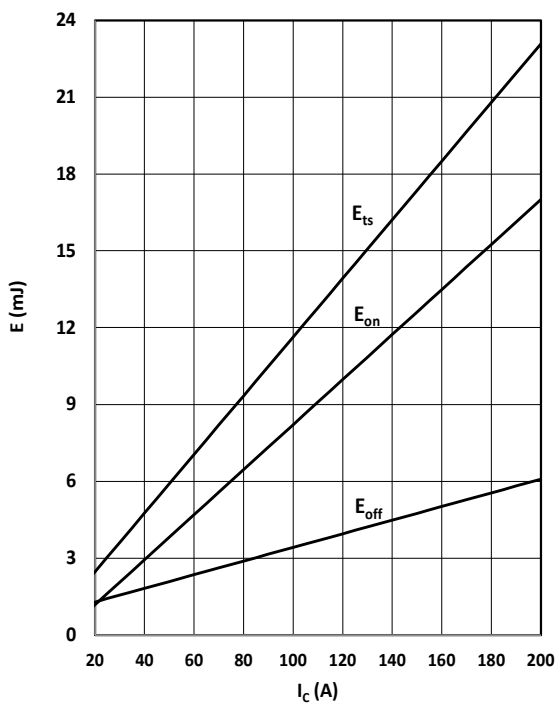

$$E = f(I_C); V_{CE} = 600\text{V}; T_j = 150^\circ\text{C}; R_G = 10\Omega$$

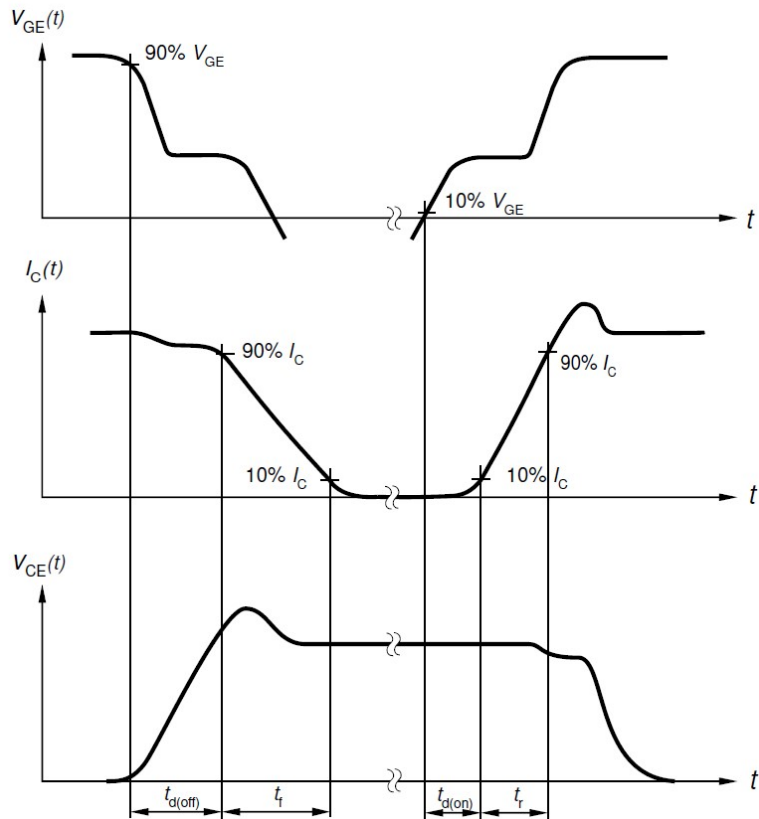
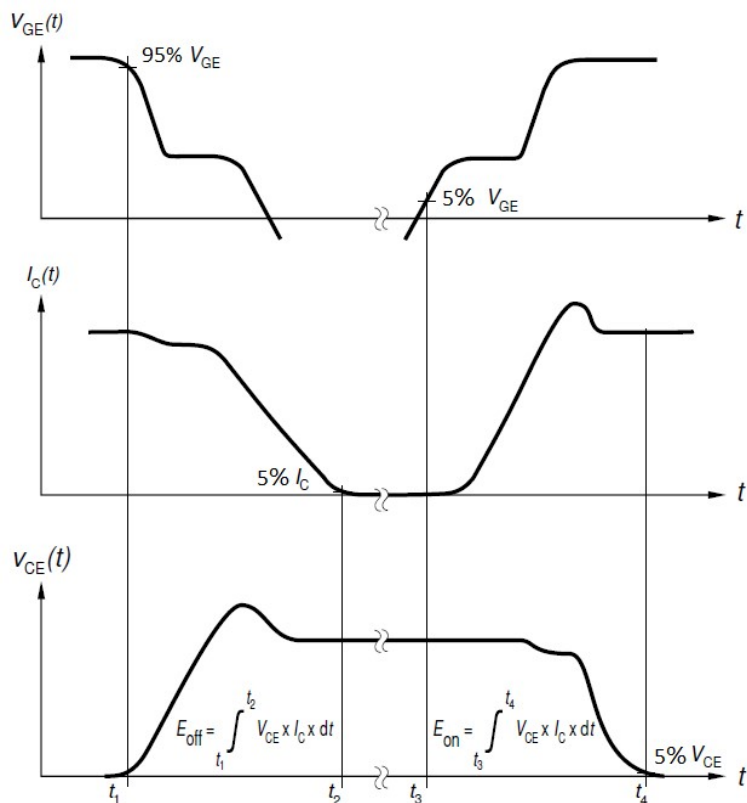
Test Circuits
1. Definition Switching times

2. Definition Switching losses

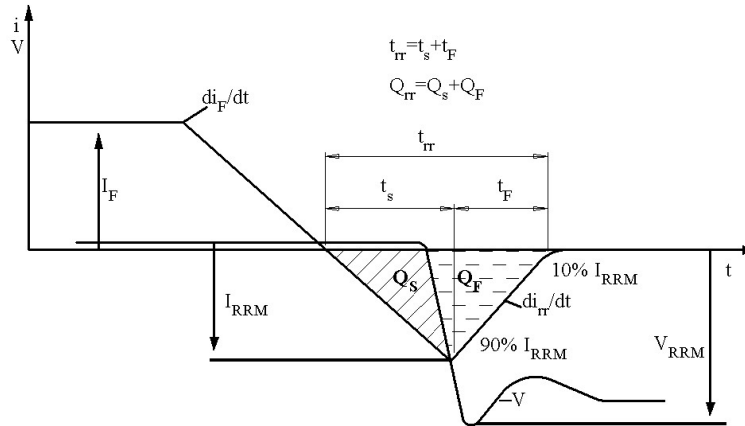
3. Definition Diode Switching Characteristics

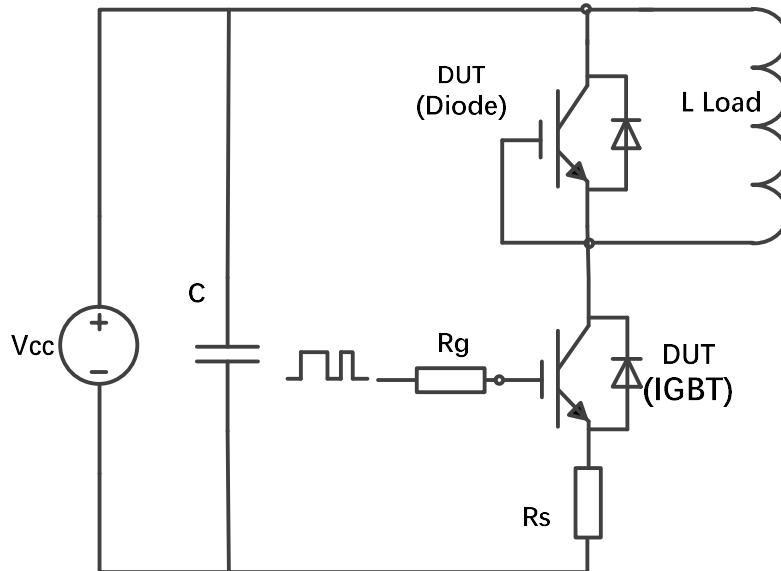

4. Dynamic test circuit



Mechanical Dimensions

TO-247Plus

Unit: mm

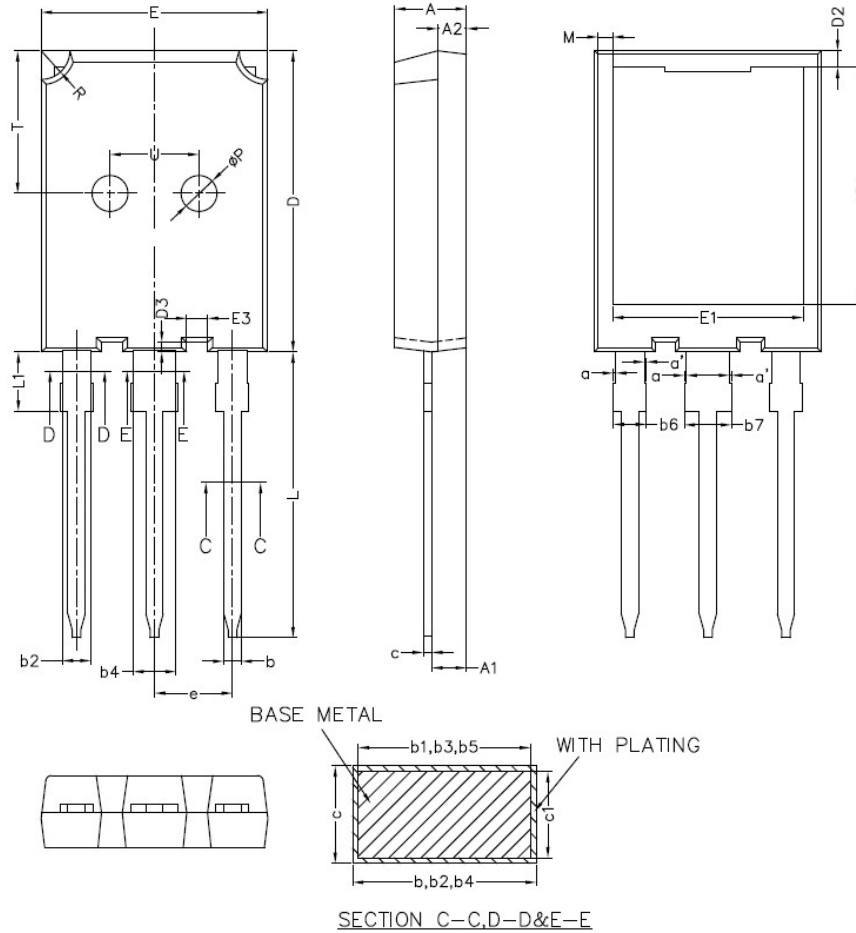

100A 1200V Trench Fieldstop IGBT with FRD
SRE100N120FSUDA

Symbol	Dimensions(mm)		
	Min.	Typ.	Max.
A	4.90	5.00	5.10
A1	2.31	2.41	2.51
A2	1.90	2.00	2.10
α	0	-	0.15
α'	0	-	0.15
b	1.16	-	1.26
b1	1.15	1.2	1.22
b2	1.96	-	2.06
b3	1.95	2.00	2.02
b4	2.96	-	3.06
b5	2.95	3.00	3.02
b6	-	-	2.25
b7	-	-	3.25
c	0.59	-	0.66
c1	0.58	0.60	0.62
D	20.90	21.00	21.10
D1	16.25	16.55	16.85
D2	1.05	1.17	1.35
D3	0.58	0.68	0.78
E	15.70	15.80	15.90
E1	13.10	13.26	13.50
E3	1.35	1.45	1.55
e	5.34	5.44	5.54
L	19.80	19.92	20.10
L1	3.90	-	4.30
M	0.70	-	1.30
P	2.40	2.50	2.60
R	1.90	2.00	2.10
T	9.80	-	10.20
U	6.00	-	6.40



TM

Sanrise Tech
尚阳通

Shenzhen Sanrise Technology Co., LTD

<http://www.sanrise-tech.com>**IMPORTANT NOTICE**

Shenzhen Sanrise Technology Co., LTD. reserves the right to make changes without further notice to any products or specifications herein. Shenzhen Sanrise Technology Co., LTD. does not assume any responsibility for use of any its products for any particular purpose, nor does Shenzhen Sanrise Technology Co., LTD. assume any liability arising out of the application or use of any its products or circuits. Shenzhen Sanrise Technology Co., LTD. does not convey any license under its patent rights or other rights nor the rights of others.

Main Site:**- Headquarter**

Shenzhen Sanrise Technology Co., LTD.
A1206, Skyworth building, No. 008, gaoxinnan 1st
Road, Gaoxin District, Yuehai street, Nanshan District,
ShenZhen, P.R. China
Tel: +86-755-22953335
Fax: +86-755-22916878

- Shanghai Office

Shenzhen Sanrise Technology Co., LTD.
Rm.401, Building B, No. 666, Zhangheng Road,
Zhangjiang Hi-Tech Park, Shanghai, P.R.China
Tel: +86-21-68825918