

Introduction

The STM3210B-EVAL is an evaluation board for STMicroelectronics' ARM™ Cortex-M3 core-based STM32F10x 128K microcontrollers. It is designed as a complete development environment for the STM32F10x microcontrollers with full speed USB2.0, CAN2.0A/B compliant interface, two I²C channels, two SPI channels, three USART channels with smartcard support, internal 20KB SRAM and 128KB Flash, JTAG and SWD debugging.

With a complete range of hardware evaluations features, the STM3210B-EVAL board is designed to help developers evaluate all device peripherals (such as USB, motor control, CAN, MicroSD card, smartcard, USART) and develop their own applications. Extension connectors make it possible to easily connect a daughter board or wrapping board for a specific application.

This user manual provides information on using the STM3210B-EVAL board and its hardware features.

Figure 1. STM32F10X 128K evaluation board (STM3210B-EVAL)



Features

- Three 5V power supply options: power jack, USB connector or daughter board
- Boot from user Flash, test Flash or SRAM
- Audio play and record
- 64Mbyte MicroSD card
- Type A and Type B smartcard support
- 8Mbyte serial Flash
- I²C/SMBus compatible serial interface temperature sensor
- Two RS232 communication channels with support for RTS/CTS handshake on one channel
- IrDA transceiver
- USB 2.0 full speed connection
- CAN 2.0A/B compliant connection
- Induction motor control connector
- JTAG, SWD and trace tool support
- 240x320 TFT color LCD
- Joystick with 4-direction control and selector
- Reset, wakeup, tamper and user push buttons
- 4 LEDs
- RTC with backup battery
- Extension connector for daughter board or wrapping board

Order code

To order the STM32F10x 128K evaluation board, use the order code **STM3210B-EVAL**.

Contents

1	Hardware layout and configuration	5
1.1	LCD configuration	7
1.2	Power supply	9
1.3	Boot option	10
1.4	Clock source	10
1.5	Reset source	11
1.6	Audio	11
1.7	Serial flash	11
1.8	CAN	11
1.9	RS232	12
1.10	Motor control	12
1.11	Smartcard	13
1.12	MicroSD card	13
1.13	Temperature sensor	13
1.14	Analog input	13
1.15	IrDA	14
1.16	USB	14
1.17	Development and debug support	14
1.18	Display and input devices	15
2	Connectors	16
2.1	USB type B connector CN1	16
2.2	CAN D-type 9-pin male connector CN2	16
2.3	Analog input connector CN3	17
2.4	Power supply connector CN4	17
2.5	RS232 connector CN5 with RTS/CTS handshake support	18
2.6	RS232 connector CN6	18
2.7	JTAG debugging connector CN7	19
2.8	Audio jack CN8	19
2.9	SWD debugging connector CN9	19
2.10	Trace debugging connector CN10	20

2.11	Daughter board extension connectors CN12 and CN13	21
2.12	Motor control connector CN14	24
2.13	MicroSD connector CN15	26
2.14	Smartcard connector CN16	26
3	Schematics	28
	Appendix A STM3210B-EVAL IO assignments	41
	Revision history	45

1 Hardware layout and configuration

The STM3210B-EVAL board is designed around a STM32F103VBT6 microcontroller in a 100-pin LQFP package.

The hardware block diagram *Figure 2* shows the connections between the STM32F10x microcontroller and peripherals (LCD, SPI Flash, USART, IrDA, USB, Audio, CAN bus, RTC, smartcard, MicroSD card and motor control).

Figure 3 will help you locate these features on the evaluation board.

Figure 2. Hardware block diagram

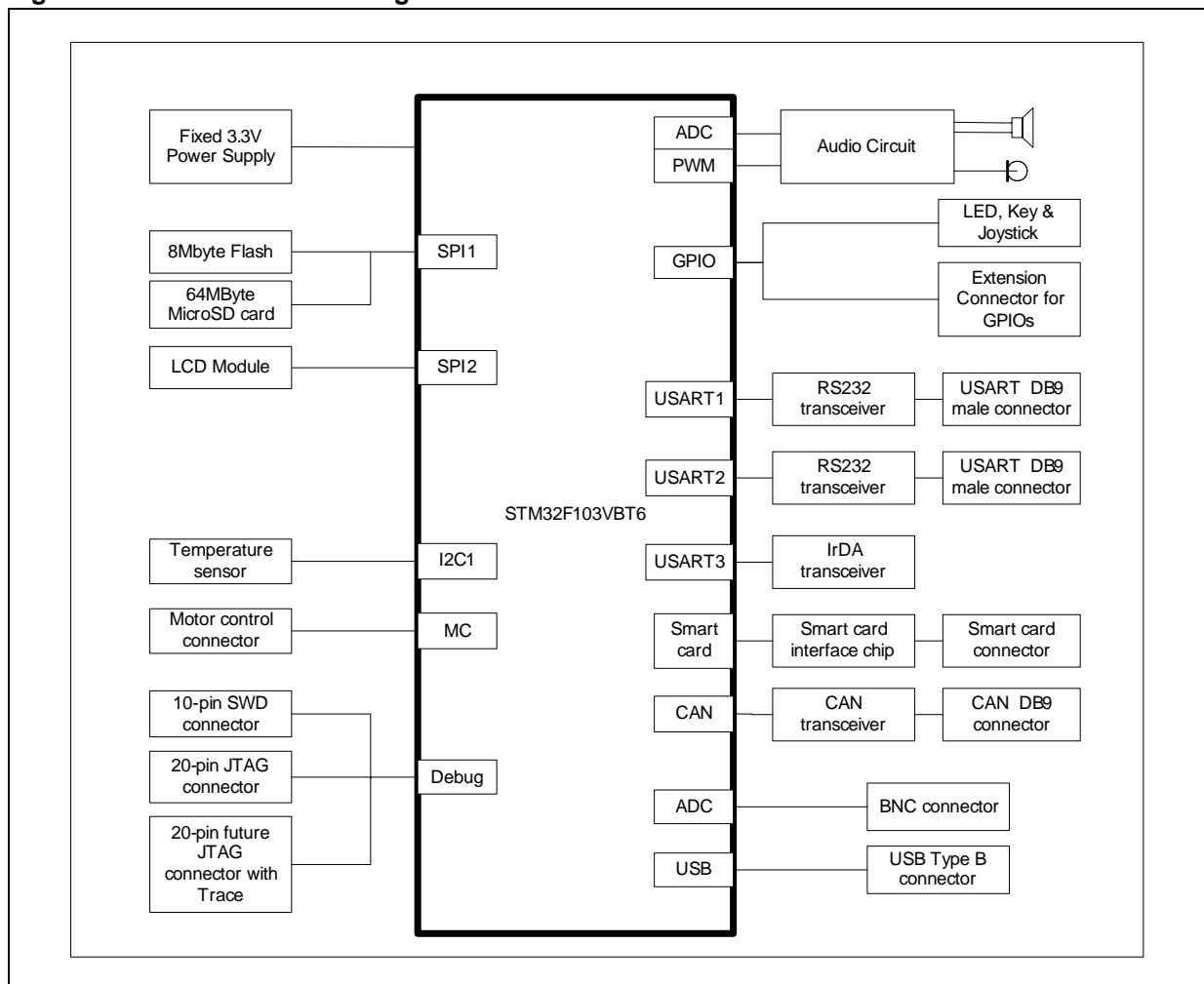
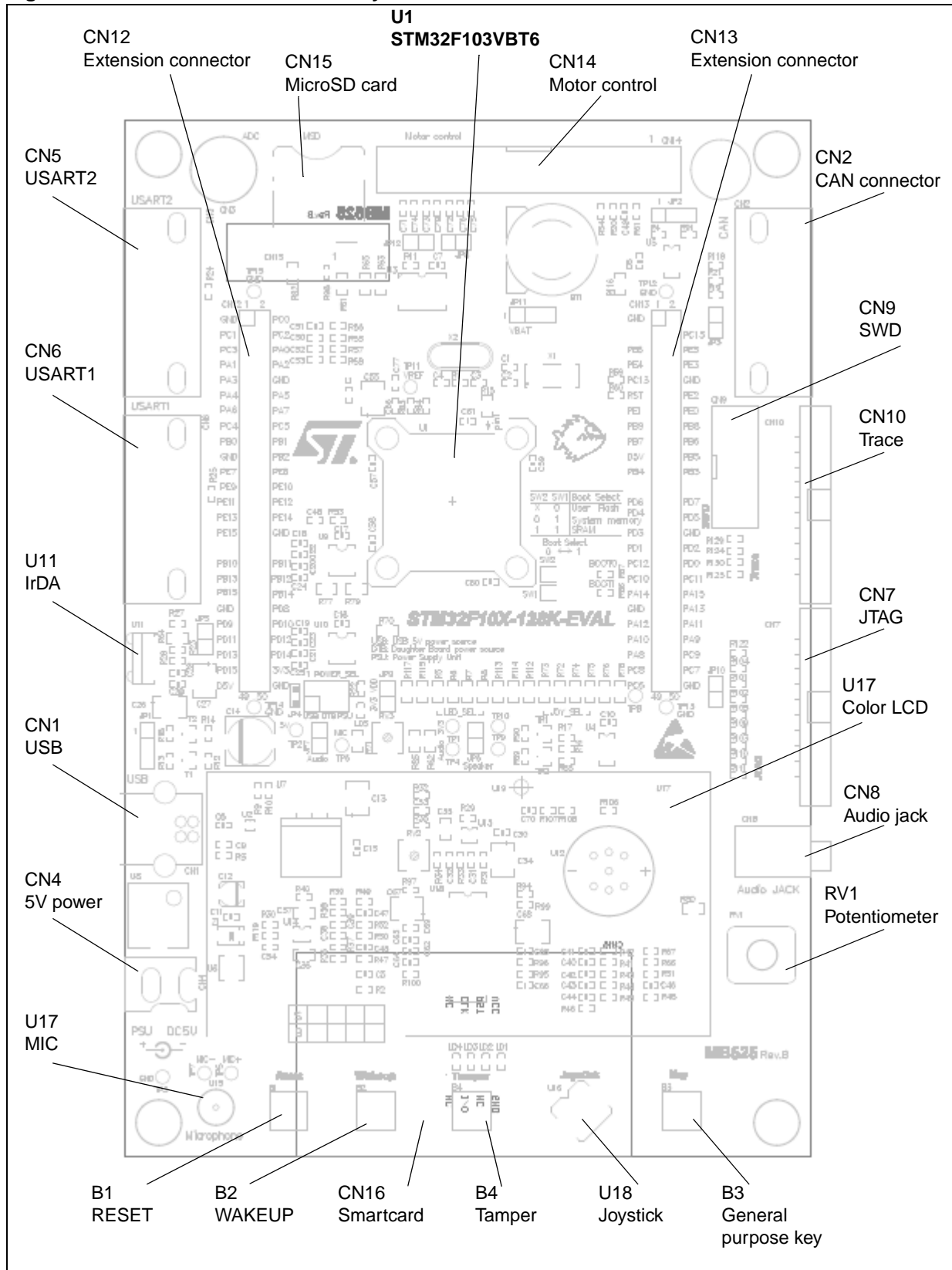


Figure 3. STM3210B-EVAL board layout

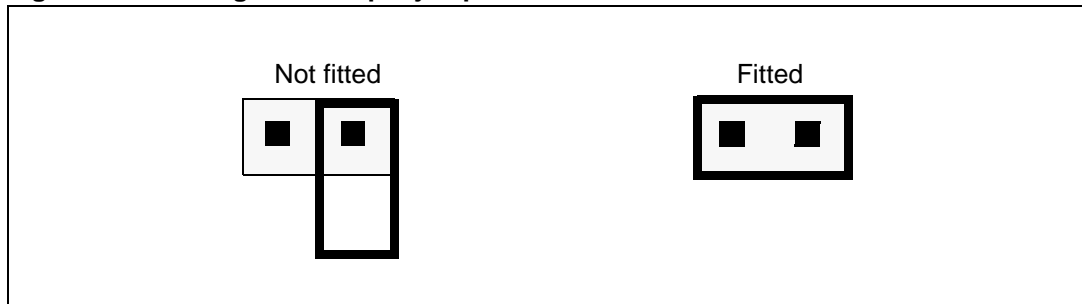


The following sections provide jumper settings for configuring your STM3210B-EVAL board and peripherals.

Two types of jumpers are used on the STM3210B-EVAL board:

- 3-pin jumpers with two possible positions, for which the possible settings are presented in schematics in the following sections
- 2-pin jumpers with two possible settings: **Fitted**– the circuit is closed, and **Not fitted**– the circuit is open (see [Figure 4](#).)

Figure 4. Settings for two-pin jumpers



1.1 LCD configuration

The STM3210B-EVAL can be delivered with either one of two LCDs mounted on the MB542 board, depending on the board version. These two LCDs look alike and operate in the same way, however they have different control circuits, and therefore require different software drivers. You must ensure that the demonstration software pre-loaded in the flash memory of the microcontroller on the evaluation board supports the LCD that you have.

If your STM3210B-EVAL product includes the **MB542 board version B-01 or later**, it is mounted with the LCD reference AM240320L8TNQW-00H (from Ampire). The controller reference is ILI9320 (from ILITEK, www.ilitek.com). The products that include this LCD have a label on the daughter board (to the left of the display) as shown in [Figure 5](#).

Figure 5. LCD label on MB542 board version B-01 or later

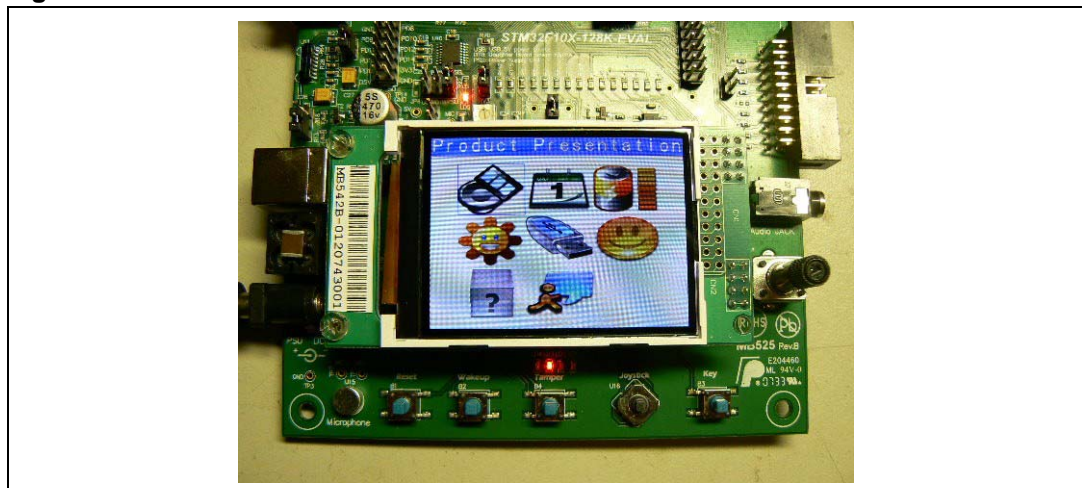


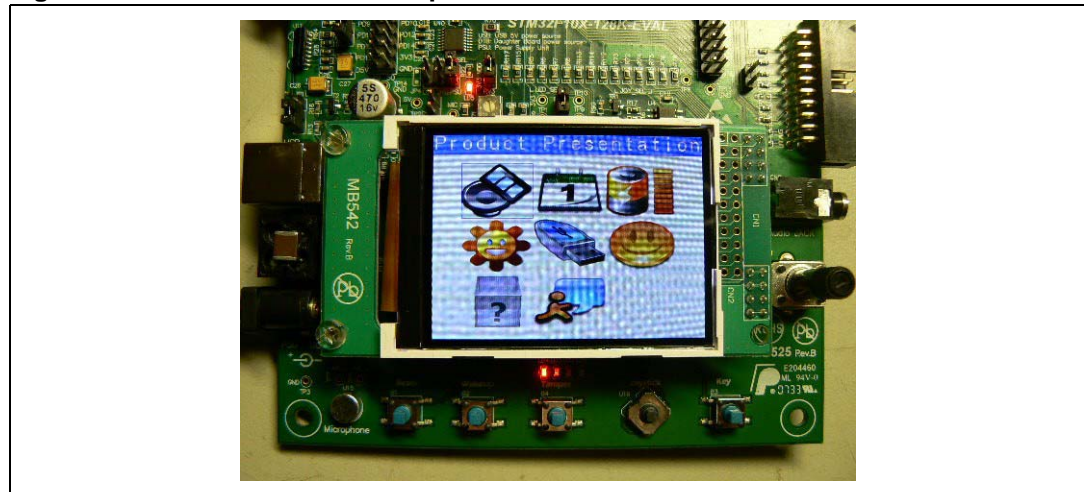
Table 1. LCD label on MB542 board version B-01 or later

Label marking	Meaning
MB542B-0120743001	LCD version B-01
B	PCB version B
01	Version 01
20743001	Board ID

The demonstration software delivered with the evaluation boards that carry this label is STM3210B-EVAL_DEMO version 1.1 or later. It automatically detects which version of the LCD is mounted on the daughter board, and it supports both.

If your STM3210B-EVAL product includes the **MB542 board version B-00 or earlier**, it is mounted with the LCD reference AM-240320LTNQW01H. The controller reference is HX8312-A (from Himax, www.himax.com.tw). The products that include this LCD do not have a label on the component side of the daughter board as shown in *Figure 6*. The label is on the solder side, therefore not visible when the MB452 board is screwed onto the MB525 board.

Figure 6. No LCD label on component side of MB542 board version B-00



The demonstration software delivered with the evaluation boards that do not carry a visible label is STM3210B-EVAL_DEMO version 1.0 or earlier. This software only supports the LCD reference AM-240320LTNQW01H.

Note: You can download the latest version of the software demonstration from the STmicroelectronics support site, www.st.com/mcu. The STM3210B-EVAL_DEMO software is included in the STM3210B-EVAL demonstration software user manual (UM0435) download file. STM3210B-EVAL_DEMO version 1.1 and later support both types of LCD.

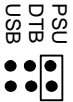
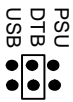
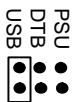
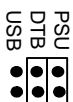


1.2 Power supply

The STM3210B-EVAL board is designed to be powered by 5V DC power supply and to be protected by PolyZen U6 in case of incorrect power supply configuration. It is possible to configure the evaluation board to use any of the following sources for the power supply.

- 5V DC power adapter connected to CN4, the power supply jack labeled “PSU” (for Power Supply Unit) on the silkscreen
- 5V DC power with 500mA limitation from CN1, the type-B USB connector on the evaluation board labeled “USB” on the silkscreen
- 5V DC power from both CN12 and CN13, the daughter board extension connectors labeled “DTB” (for Daughter Board) on the silkscreen

The power supply is configured by setting the related jumpers **JP4**, **JP9** and **JP11** as described in [Table 2](#).

Table 2. Power related jumpers

Jumper	Description
JP4	JP4 is used to select one of the three possible power supply resources. For power supply from the power supply jack (CN4) to the STM3210B-EVAL <u>only</u> , JP4 is set as shown (default setting): 
	For power supply from the daughter board connectors (CN12 and CN13) to the STM3210B-EVAL <u>only</u> , JP4 is set as shown: 
	For power supply from USB (CN1) to the STM3210B-EVAL <u>only</u> , JP4 is set as shown: 
	For power supply from power supply jack (CN4) to both the STM3210B-EVAL board and to a daughter board connected on CN12 and CN13, JP4 is set as shown below. The daughter board must not have its own power supply connected. 
JP9	Measures the consumption of VDD and VDDA. Default setting: Fitted
JP11	 V _{bat} is connected to 3.3V power when JP11 is set as shown (default setting):
	 V _{bat} is connected to battery when JP11 is set as shown:

The LED LD5 is lit when the STM3210B-EVAL board is powered correctly.

1.3 Boot option

The STM3210B-EVAL board is able to boot from:

- Embedded user Flash
- System memory with boot loader for ISP
- Embedded SRAM for debugging

The boot option is configured by setting the switches SW1 and SW2 as shown in [Table 3](#). The two possible positions of these micro switches are shown in [Figure 7](#).

Figure 7. Switch positions

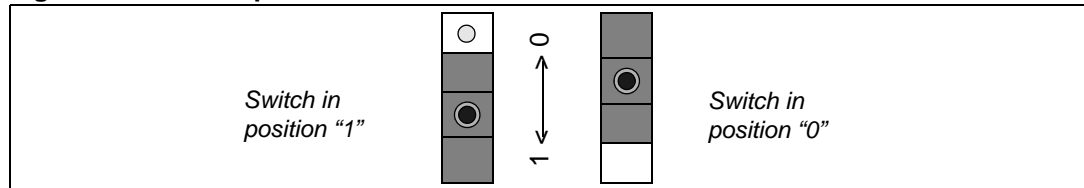


Table 3. Boot switches

Switch	Boot from	Switch configuration
SW1 SW2	STM3210B-EVAL boots from user Flash when SW2 is set as shown to the right (default setting). In this configuration, the position of SW1 doesn't affect the boot process. Boot 0 = 0, Boot 1 = X	
	STM3210B-EVAL boots from embedded SRAM when SW1 and SW2 are set as shown to the right. Boot 0 = 1, Boot 1 = 1	
	STM3210B-EVAL boots from system memory when SW1 and SW2 are set as shown to the right. Boot 0 = 1, Boot 1 = 0	

1.4 Clock source

Two clock sources are available on the STM3210B-EVAL board for the STM32F10X microcontroller and RTC.

- X1, 32KHz crystal for embedded RTC
- X2, 8MHz crystal with socket for the STM32F10X microcontroller. It can be removed from the socket when the internal RC clock is used.

1.5 Reset source

The reset signal of the STM3210B-EVAL board is active low and the reset sources include:

- Reset button B1
- Debugging tools from connector CN7, CN9 and CN10
- Daughter board from CN13

Table 4. Reset jumper

Jumper	Description
JP10	Enables reset of the STM32F10X microcontroller embedded JTAG TAP controller each time a system reset occurs. JP10 connects the TRST signal from the JTAG connection with the system reset signal RESET#. Default setting: Not fitted

1.6 Audio

The STM3210B-EVAL board supports both audio recording and playback. This can be disabled or enabled by setting the jumpers JP6 and JP7. The audio volume can be adjusted using the potentiometer RV2, and the microphone amplifier gain can be adjusted using the potentiometer RV3.

Table 5. Audio jumpers

Jumper	Description
JP6	Audio power amplifier TS4871 is forced into standby mode when JP6 is not fitted. Default setting: Fitted
JP7	Microphone pre-amplifier MAX4061 is forced into shutdown mode when JP7 is fitted. Default setting: Not fitted



1.7 Serial flash

A 64Mbit serial flash connected to SPI1 of the STM32F10X microcontroller shares the same SPI port with the MicroSD card using a different chip select signal. Serial Flash Chip select is managed by the standard IO port PA4.

1.8 CAN

The STM3210B-EVAL board supports CAN 2.0A/B compliant CAN bus communication based on 3.3V CAN transceiver. The high-speed mode, standby mode and slope control mode are available and selected by setting JP2.

Table 6. CAN jumpers

Jumper	Description
JP2	CAN transceiver functions in standby mode when JP2 is set as shown below: <div style="text-align: center;">  </div>
	CAN transceiver functions in high-speed mode when JP2 is set as shown below: <div style="text-align: center;">  </div>
	CAN transceiver functions in slope control mode when JP2 is not fitted. (Default setting)
JP3	CAN terminal resistor is enabled when JP3 is fitted. Default setting: Not fitted

1.9 RS232

Two Type D 9-pin connectors, CN6 (USART1) and CN5 (USART2) are available on the STM3210B-EVAL board. The USART1 connector is connected to the RS232 transceiver U10, and the USART2 connector with RTS/CTS handshake signal support is connected to the RS232 transceiver U9.

1.10 Motor control

The STM3210B-EVAL board supports induction motor control via a 34-pin connector, CN14, which provides all required control and feedback signals to and from a motor power-drive board. Available signals on this connector include emergency stop, motor speed, 3-phase motor current, bus voltage, heatsink temperature coming from the motor drive board and 6 channels of PWM control signals going to the motor drive circuit.

Special motor current sampling operation is enabled by setting jumper JP8.

Table 7. Motor control jumpers

Jumper	Description
JP8	Enables special motor current sampling operation when JP8 is fitted (PD2 connected to PB0). The IO pins PD2 and PB0 are disconnected and can be used by the daughter board when JP8 is not fitted. Default setting: Fitted
JP12	JP12 must be open when the digital encoder signal comes from pin31 of CN14. It must be closed when an analog signal comes from pin31 of CN14. Default setting: Not fitted (open)

1.11 Smartcard

The STMicroelectronics smartcard interface device ST8024 is used on the STM3210B-EVAL board for asynchronous 3V and 5V smartcards. It performs all supply protection and control functions based on the connections with the STM32F10X microcontroller, which are listed in [Table 8](#).

Table 8. Connection between ST8024 and STM32F10X

ST8024 signals	Description	Connect to STM32F10X
5V/3V	Smartcard power supply selection pin	PD11
I/OUC	MCU data I/O line	PB10
XTAL1	Crystal or external clock input	PB12
OFF	Detect presence of a card, Interrupt to MCU	PE14
RSTIN	Card reset input from MCU	PB11
CMDVCC	Start activation sequence input (active low)	PE7

An example of smartcard is provided with the board called *GSM file system sample*. With this board, you can play basic commands, select a file and do simple read/write operations to become familiar with this interface and the ISO/IEC 7816-3 protocol.

1.12 MicroSD card

The 64Mbyte or 128Mbyte MicroSD card, which is connected to SPI1 of the STM32F10x microcontroller (shared with serial Flash), is available on the board. The MicroSD card chip selection is managed by the standard IO port PC12.

1.13 Temperature sensor

One I²C interface temperature sensor STLM75 (–55°C to +125°C), which is connected to I²C1 of the STM32F10x microcontroller, is available on the board. Two discrete N-channel enhancement MOS-FETs are used to demonstrate how different voltage level devices can be connected to the same I²C bus.

1.14 Analog input

One BNC connector, CN3, is connected to PC1, the ADC channel 11 of the STM32F10x microcontroller as an external analog input.

1.15 IrDA

IrDA communication is supported by the IrDA transceiver U11, which is connected to USART3 of the STM32F10x microcontroller. It can be enabled or disabled by setting the jumper JP5.



Table 9. IrDA jumpers

Jumper	Description
JP5	Enables/disables the IrDA transceiver. IrDA is enabled when JP5 is fitted, and disabled when JP5 is not fitted. Default setting: Fitted

1.16 USB

The STM3210B-EVAL board supports USB2.0 compliant full-speed communication via a USB type B connector (CN1). The evaluation board can be powered by this USB connection at 5V DC with a 500mA current limitation. USB disconnect simulation can be implemented by disconnecting a 1.5K pull-up register from the USB+ line. The USB disconnect simulation feature is enabled by setting JP1.

Table 10. USB jumpers

Jumper	Description
JP1	USB 1.5K pull-up register is always connected to USB+ line when JP1 is set as shown. 
	USB 1.5K pull-up register can be disconnected by software from the USB+ line when JP1 is set as shown (default setting). In this case, USB connect/disconnect features are managed by the standard IO port PD9. 

1.17 Development and debug support

The following debug connectors are available on the STM3210B-EVAL board:

- CN7, an industry standard 20-pin JTAG interface connector for connection of debugging/programming tools for ARM7 and ARM9 core-based devices.
- CN9, a 10-pin SWD debug connector that supports the new Serial Wire Debug feature of ARM Cortex-M3 devices.
- CN10, a 20-pin connector for legacy and future JTAG tools that are compliant with ARM CoreSight.

1.18 Display and input devices

The 240x320 TFT color LCD (U17) and 4 general purpose LEDs (LD1, 2, 3, 4) are available as display devices. A 4-direction joystick with selection key, general purpose pushbutton (B3), wakeup button (B2) and tamper detection button (B4) are available as input devices.

The STM3210B-EVAL board also supports a second optional 122x32 graphic LCD that can be mounted on the U19 connector. The graphic LCD is not provided.

Table 11. LCD modules

Graphic LCD U17 (default)			Character LCD U19 (optional)		
Pin on U17	Description	Pin connection	Pin on U19	Description	Pin connection
1	CS	PB2	1	Vss	GND
2	SCL	PB13	2	Vcc	+3.3V
3	SDI	PB15	3	VO	-
4	RS	PD7	4	CLK	PB13
5	WR	PD15	5	SID	PB15
6	RD	GND	6	CS	PB2
7	SDO	PB14	7	A	+5V
8	RESET#	RESET#	8	K	GND
9	VDD	+3V3			
10	VCI	+3V3			
11	GND	GND			
12	GND	GND			
13	BL_VDD	+3V3			
14	BL_Control	PA8			
15	BL_GND	GND			
16	BL_GND	GND			

2 Connectors

2.1 USB type B connector CN1

Figure 8. USB type B connector CN1 (front view)

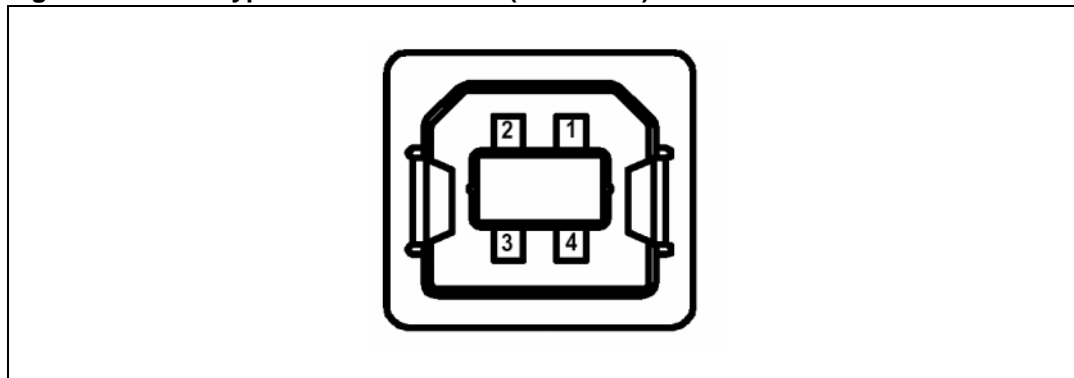


Table 12. USB type B connector (CN1)

Pin number	Description	Pin number	Description
1	VBUS(power)	4	GND
2	DM	5, 6	Shield
3	DP		

2.2 CAN D-type 9-pin male connector CN2

Figure 9. CAN D-type 9-pin male connector CN2 (front view)

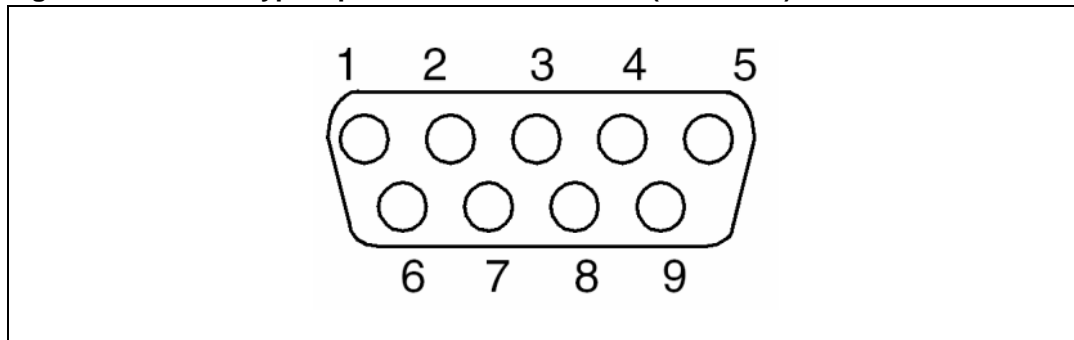


Table 13. CAN D-type 9-pin male connector (CN2)

Pin number	Description	Pin number	Description
1, 4, 8, 9	NC	7	CANH
2	CANL	3, 5, 6	GND

2.3 Analog input connector CN3

Figure 10. Analog input connector CN3 (top view)

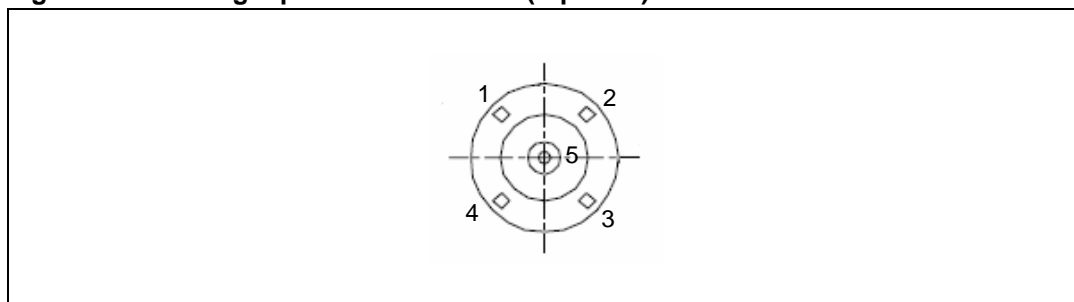


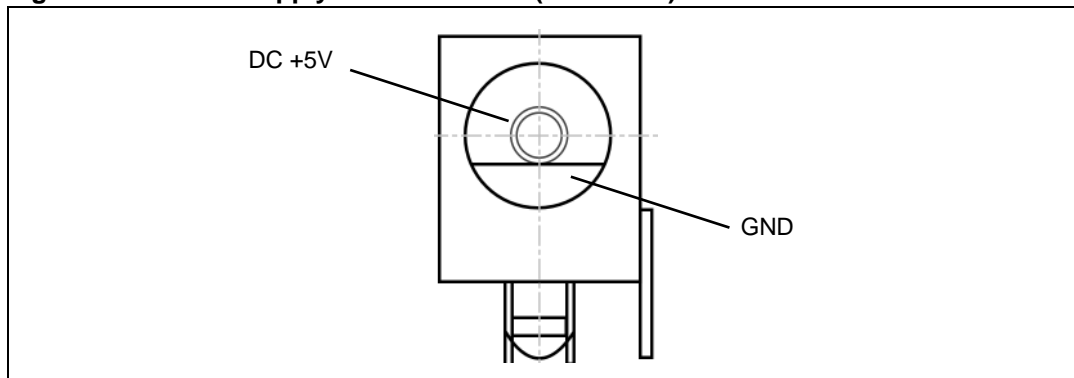
Table 14. Analog input connector CN3

Pin number	Description	Pin number	Description
1	GND	4	GND
2	GND	5	Analog input/PC1
3	GND		

2.4 Power supply connector CN4

The STM3210B-EVAL board can be powered from a DC 5V power supply via the external power supply jack (CN4) shown in [Figure 11](#). The central pin of CN4 must be positive.

Figure 11. Power supply connector CN4 (front view)



2.5 RS232 connector CN5 with RTS/CTS handshake support

Figure 12. RS232 connector CN5 with RTS/CTS handshake support (front view)

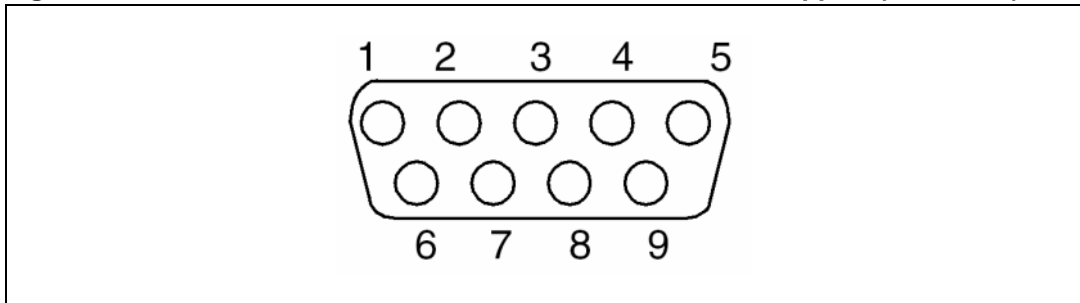


Table 15. RS232 connector CN5 with full modem control support

Pin number	Description	Pin number	Description
1	NC	6	Connect to Pin 4
2	USART2_RXD	7	USART2_RTS
3	USART2_TXD	8	USART2_CTS
4	Connect to Pin 6	9	NC
5	GND		

2.6 RS232 connector CN6

Figure 13. RS232 connector CN6 (front view)

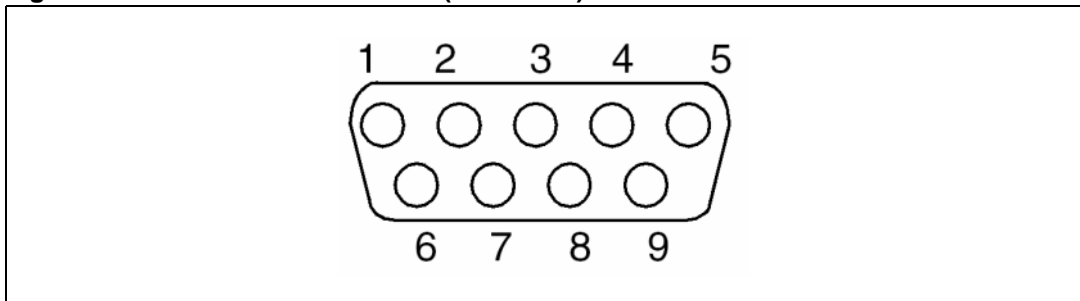


Table 16. RS232 connector CN6

Pin number	Description	Pin number	Description
1	NC	6	Connect to Pin 4
2	USART1_RXD	7	Connect to Pin 8
3	USART1_TXD	8	Connect to Pin 7
4	Connect to Pin 6	9	NC
5	GND		

2.7 JTAG debugging connector CN7

Figure 14. JTAG debugging connector CN7 (front view)

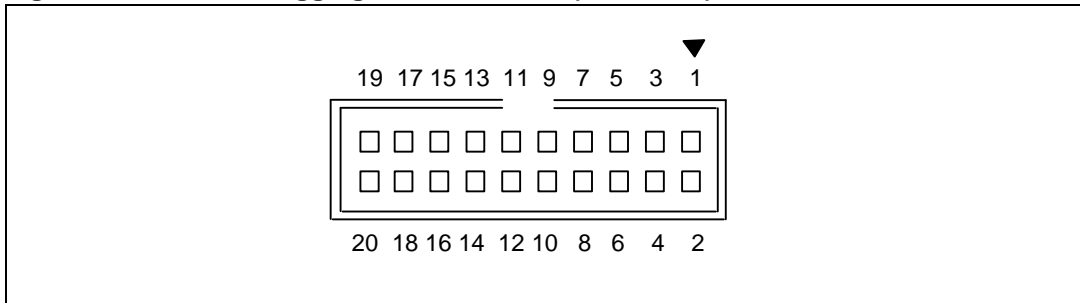


Table 17. JTAG debugging connector

Pin number	Description	Pin number	Description
1	3.3V power	2	3.3V power
3	TRST	4	GND
5	TDI	6	GND
7	TMS	8	GND
9	TCK	10	GND
11	RTCK	12	GND
13	TDO	14	GND
15	RESET#	16	GND
17	DBGRRQ	18	GND
19	DBGACK	20	GND

2.8 Audio jack CN8

A 3.5mm mono audio jack CN8 is available on the STM3210B-EVAL board. The speaker U12 is bypassed when earphones are plugged into CN8.

2.9 SWD debugging connector CN9

Figure 15. SWD debugging connector CN9 (top view)

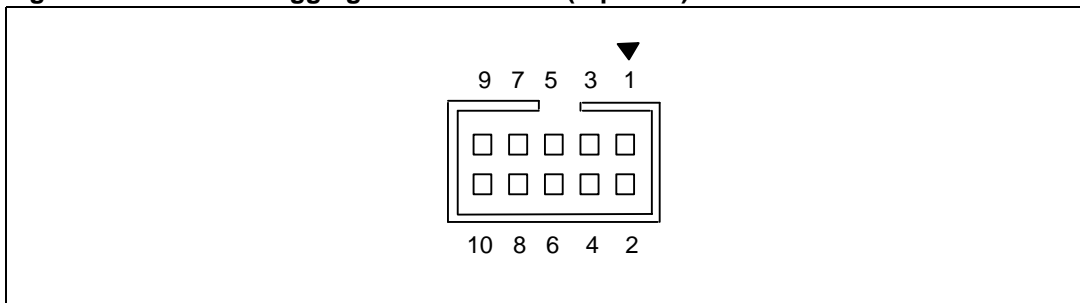


Table 18. SWD debugging connector (CN9)

Pin number	Description	Pin number	Description
1	+3V3	2	SWDIO/PA13
3	GND	4	SWCLK/PA14
5	GND	6	SWO/PB3
7	GND	8	TDI/PA15
9	GND	10	RESET#

2.10 Trace debugging connector CN10

Figure 16. Trace debugging connector CN10 (front view)

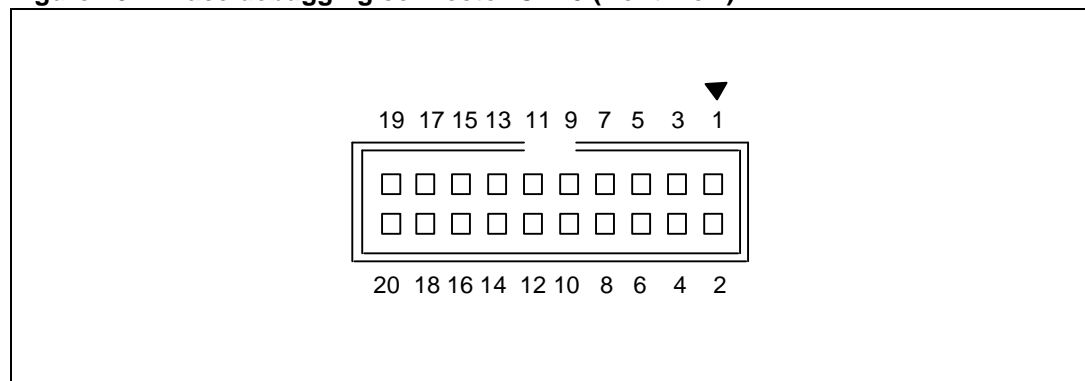


Table 19. Trace debugging connector (CN10)

Pin number	Description	Pin number	Description
1	3.3V power	2	TMS/PA13
3	GND	4	TCK/PA14
5	GND	6	TDO/PB3
7	GND	8	TDI/PA15
9	GND	10	RESET#
11	GND	12	TraceCLK/PE2
13	GND	14	TraceD0/PE3 or SWO/PB3
15	GND	16	TraceD1/PE4 or nTRST/PB4
17	GND	18	TraceD2/PE5
19	GND	20	TraceD3/PE6

2.11 Daughter board extension connectors CN12 and CN13

Two 50-pin male headers, CN12 and CN13, can be used to connect a daughter board or standard wrapping board to the STM3210B-EVAL board. A total of 80 GPIOs are available on these connectors. Each pin on CN12 and CN13 can be used by a daughter board after disconnecting it from the corresponding function block on the STM3210B-EVAL board. Refer to [Table 20](#) and [Table 21](#) for details.

Table 20. Daughter board extension connector CN12

Pin	Description	Alternate function	How to disconnect from function block on STM3210B-EVAL board
1	GND	-	-
3	PC1	MC connector pin 15	Disconnect STM3210B-EVAL board from motor power drive board
5	PC3	MC connector pin 19	Disconnect STM3210B-EVAL board from motor power drive board
7	PA1	MC connector pin 33	Disconnect STM3210B-EVAL board from motor power drive board
9	PA3	MC connector pin 14	Disconnect STM3210B-EVAL board from motor power drive board
11	PA4	SPI Flash	Remove R63
13	PA6	SPI Flash & MicroSD card	Remove R65 and R82
15	PC4	Potentiometer RV1	Remove R80
17	PB0	MC connector pin 27	JP8 is not fitted
19	GND	-	-
21	PE7	Smartcard	-
23	PE9	MC connector pin 3	Disconnect STM3210B-EVAL board from motor power drive board
25	PE11	MC connector pin 7	Disconnect STM3210B-EVAL board from motor power drive board
27	PE13	MC connector pin 11	Disconnect STM3210B-EVAL board from motor power drive board
29	PE15	MC connector pin 1	Remove R53
31	NC	-	-
33	PB10	Smartcard	Remove R115
35	PB13	LCD	-
37	PB15	LCD	-
39	GND	-	-
41	PD9	USB	Disconnect JP1
43	PD11	Smartcard	-
45	PD13	MC connector pin 23	Disconnect STM3210B-EVAL board from motor power drive board

Table 20. Daughter board extension connector CN12 (continued)

Pin	Description	Alternate function	How to disconnect from function block on STM3210B-EVAL board
47	PD15	LCD	-
49	D5V	-	-
2	PC0	MC connector pin 26	Disconnect STM3210B-EVAL board from motor power drive board
4	PC2	MC connector pin 17	Disconnect STM3210B-EVAL board from motor power drive board
6	PA0	MC connector pin 31 & wakeup button	Disconnect STM3210B-EVAL board from motor power drive board Remove R85
8	PA2	MC connector pin 34	Disconnect STM3210B-EVAL board from motor power drive board
10	GND	-	-
12	PA5	SPI Flash & MicroSD card	-
14	PA7	SPI Flash & MicroSD card	-
16	PC5	Microphone	Remove R71
18	PB1	MC connector pin 29	Disconnect STM3210B-EVAL board from motor power drive board
20	PB2	BOOT & LCD	-
22	PE8	MC connector pin 5	Disconnect STM3210B-EVAL board from motor power drive board
24	PE10	MC connector pin 9	Disconnect STM3210B-EVAL board from motor power drive board
26	PE12	MC connector pin 13	Disconnect STM3210B-EVAL board from motor power drive board
28	PE14	Smartcard	Remove R117
30	GND	-	-
32	NC	-	-
34	PB11	Smartcard	-
36	PB12	Smartcard	-
38	PB14	LCD	Remove LCD module
40	PD8	Joystick Up	Remove R76
42	PD10	MC connector pin 21	Disconnect STM3210B-EVAL board from motor power drive board
44	PD12	Joystick selection	Remove R72
46	PD14	Joystick Down	Remove R73

Table 20. Daughter board extension connector CN12 (continued)

Pin	Description	Alternate function	How to disconnect from function block on STM3210B-EVAL board
48	+3V3	-	-
50	GND	-	-

Table 21. Daughter board extension connector CN13

Pin	Description	Alternate function	How to disconnect from component on STM3210B-EVAL board
1	GND	-	-
3	NC		
5	PE6	Debug TraceD3	-
7	PE4	Debug TraceD1	-
9	PC13	Tamper key	-
11	RESET#	RESET# button	-
13	PE1	Joystick Left	Remove R74
15	PB9	User button	Remove R78
17	PB7	Temperature sensor	Remove R114
19	D5V	-	-
21	PB4	Debug nTRST	JP10 is not fitted
23	NC	-	-
25	PD6	USART2	Remove R77
27	PD4	USART2	-
29	PD3	USART2	Remove R79
31	PD1	CAN_TX	-
33	PC12	MicroSD card	Remove R81
35	PC10	IrDA	-
37	PA14	Debug TCK	-
39	GND	-	-
41	PA12	USB	-
43	PA10	USART1_RX	Remove R70
45	PA8	LCD	-
47	PC8	LED3	Remove R6
49	PC6	LED1	Remove R8
2	NC		
4	PC13	Tamper button	Remove R62
6	PE5	Debug TraceD2	-
8	PE3	Debug TraceD0	-

Table 21. Daughter board extension connector CN13 (continued)

Pin	Description	Alternate function	How to disconnect from component on STM3210B-EVAL board
10	GND	-	-
12	PE2	Debug trace CLK	-
14	PE0	Joystick Right	Remove R75
16	PB8	Speaker	Unfitted JP6
18	PB6	Temperature sensor	Remove R113
20	PB5	Temperature sensor	Remove R112
22	PB3	Debug SWO	-
24	NC	-	-
26	PD7	LCD	-
28	PD5	USART2	-
30	GND	-	-
32	PD2	MC connector pin 27	Disconnect STM3210B-EVAL board from motor power drive board
34	PD0	CAN_RX	Remove R116
36	PC11	IrDA	Remove R64
38	PA15	Debug TDI	-
40	PA13	Debug TMS	-
42	PA11	USB	-
44	PA9	USART1_TX	-
46	PC9	LED4	Remove R5
48	PC7	LED2	Remove R7
50	GND	-	-

2.12 Motor control connector CN14

Figure 17. Motor control connector CN14 (top view)

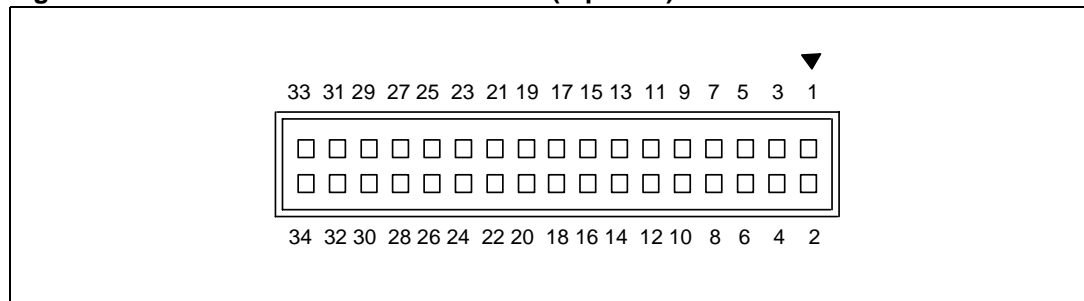


Table 22. Motor control connector CN14

Description	Pin of STM32F10X	Pin number on CN1	Pin number on CN1	Pin of STM32F10x	Description
EMERGENCY STOP	PE15	1	2		GND
PWM-UH	PE9	3	4		GND
PWM-UL	PE8	5	6		GND
PWM-VH	PE11	7	8		GND
PWM-VL	PE10	9	10		GND
PWM-WH	PE13	11	12		GND
PWM-WL	PE12	13	14	PA3	BUS VOLTAGE
PHASE A CURRENT	PC1	15	16		GND
PHASE B CURRENT	PC2	17	18		GND
PHASE C CURRENT	PC3	19	20		GND
NTC BYPASS RELAY	PD10	21	22		GND
DISSIPATIVE BRAKE PWM	PD13	23	24		GND
+5V power		25	26	PC0	Heatsink temperature
PFC SYNC	PD2/PB0	27	28		3.3V power
PFC PWM	PB1	29	30		GND
Encoder A	PA0	31	32		GND
Encoder B	PA1	33	34	PD14	Encoder Index

2.13 MicroSD connector CN15

Figure 18. MicroSD connector CN15 (top view)

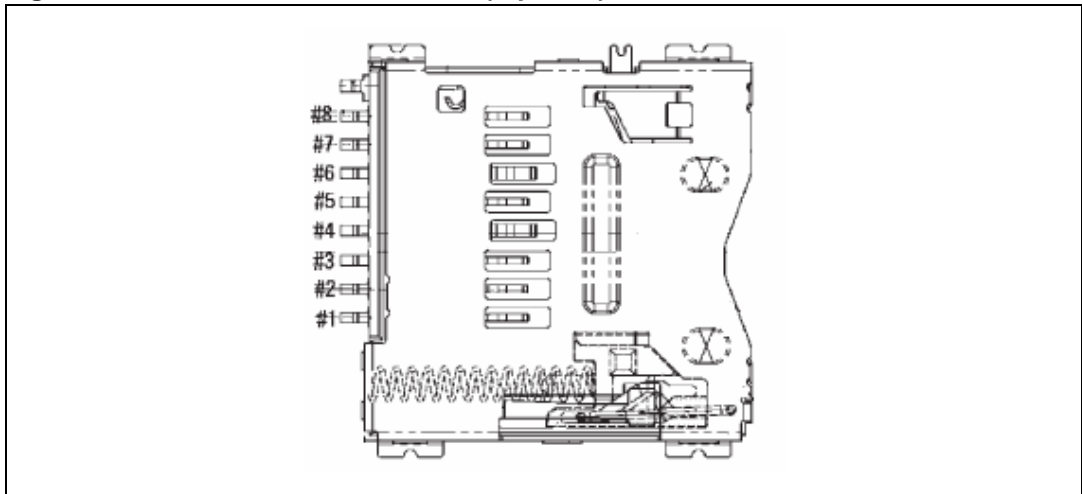


Table 23. MicroSD connector CN15

Pin number	Description	Pin number	Description
1	Reserved	5	SCLK/PA5
2	CS/PC12	6	Vss/GND
3	DI/PA7	7	DO/PA6
4	VDD	8, 9	Reserved

2.14 Smartcard connector CN16

Figure 19. Smartcard connector CN16 (top view of connector underneath PCB)

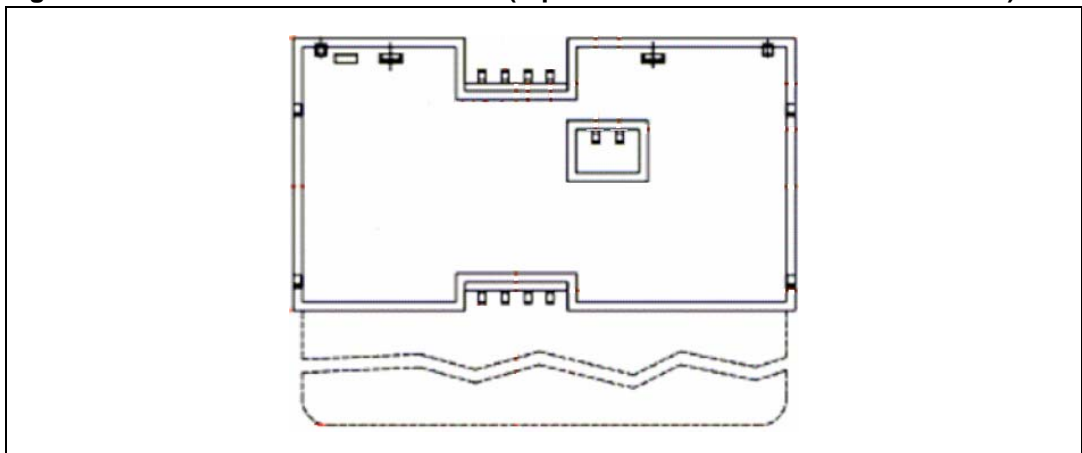


Table 24. Smartcard connector CN16

Pin number	Description	Pin number	Description
1	VCC	5	GND
2	RST	6	NC
3	CLK	7	I/O
4	NC	8	NC
17	Card presence detection pin	18	Card presence detection pin

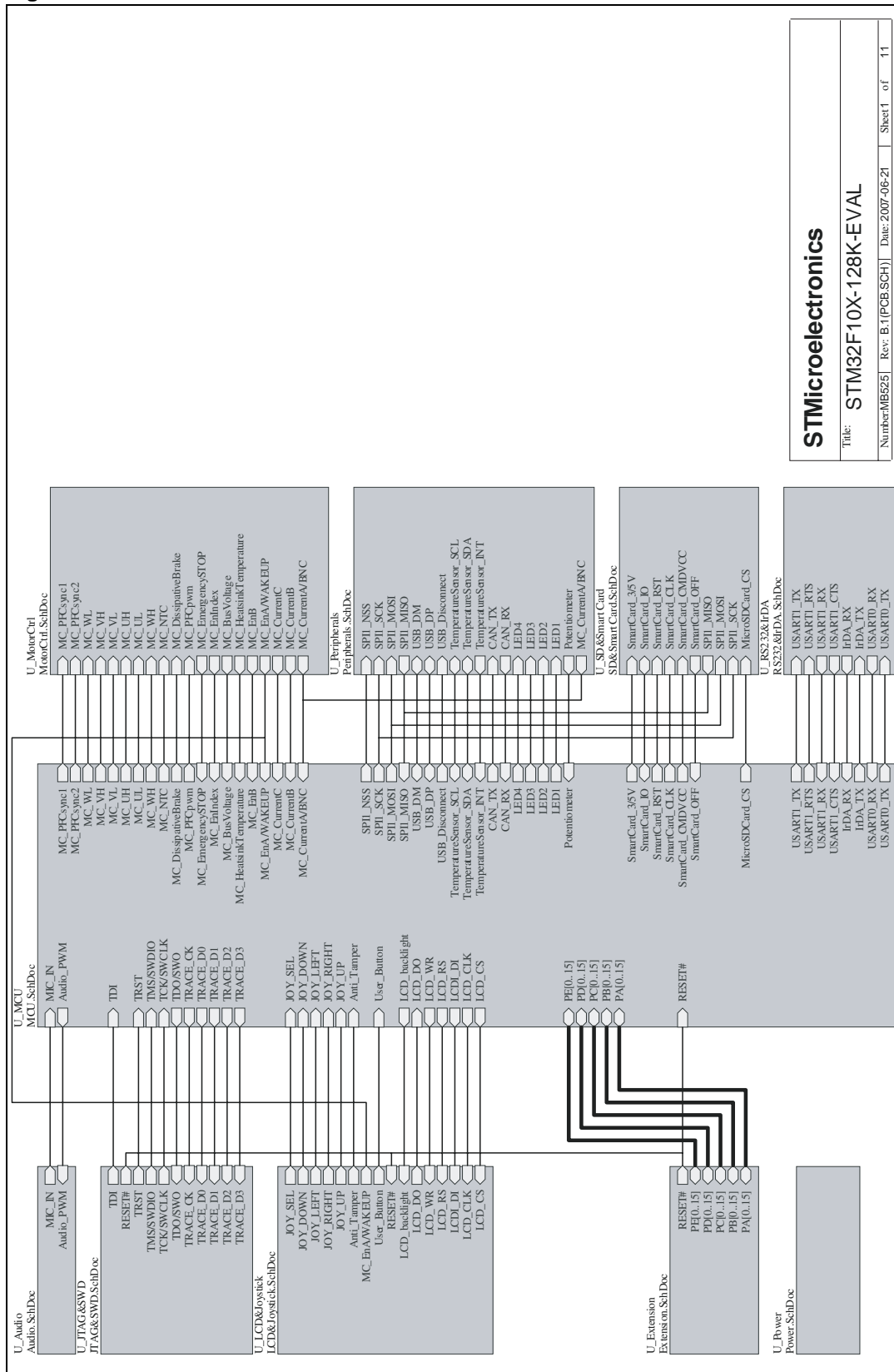
3 Schematics

This section provides design schematics for the STM3210B-EVAL key features to help you implement these features in your own application designs.

This section includes:

- Overall schematics for the board, see [Figure 20](#)
- MCU connections, see [Figure 21](#)
- EEPROM, USB, LED, CAN and temperature sensor, see [Figure 22](#)
- USART1, USART2, IrDA, see [Figure 23](#)
- Audio amplifier and micro amplifier, see [Figure 24](#)
- Joystick, LCD, tamper button, wakeup button, user button, see [Figure 25](#)
- Smartcard and MicroSD card, [Figure 26](#)
- Motor control, [Figure 27](#)
- JTAG, SWD debugger, see [Figure 28](#)
- Power supply, see [Figure 29](#)
- Extension connectors, see [Figure 30](#)
- MB542 daughter board schematics, see [Figure 31](#)

Figure 20. Evaluation board schematics



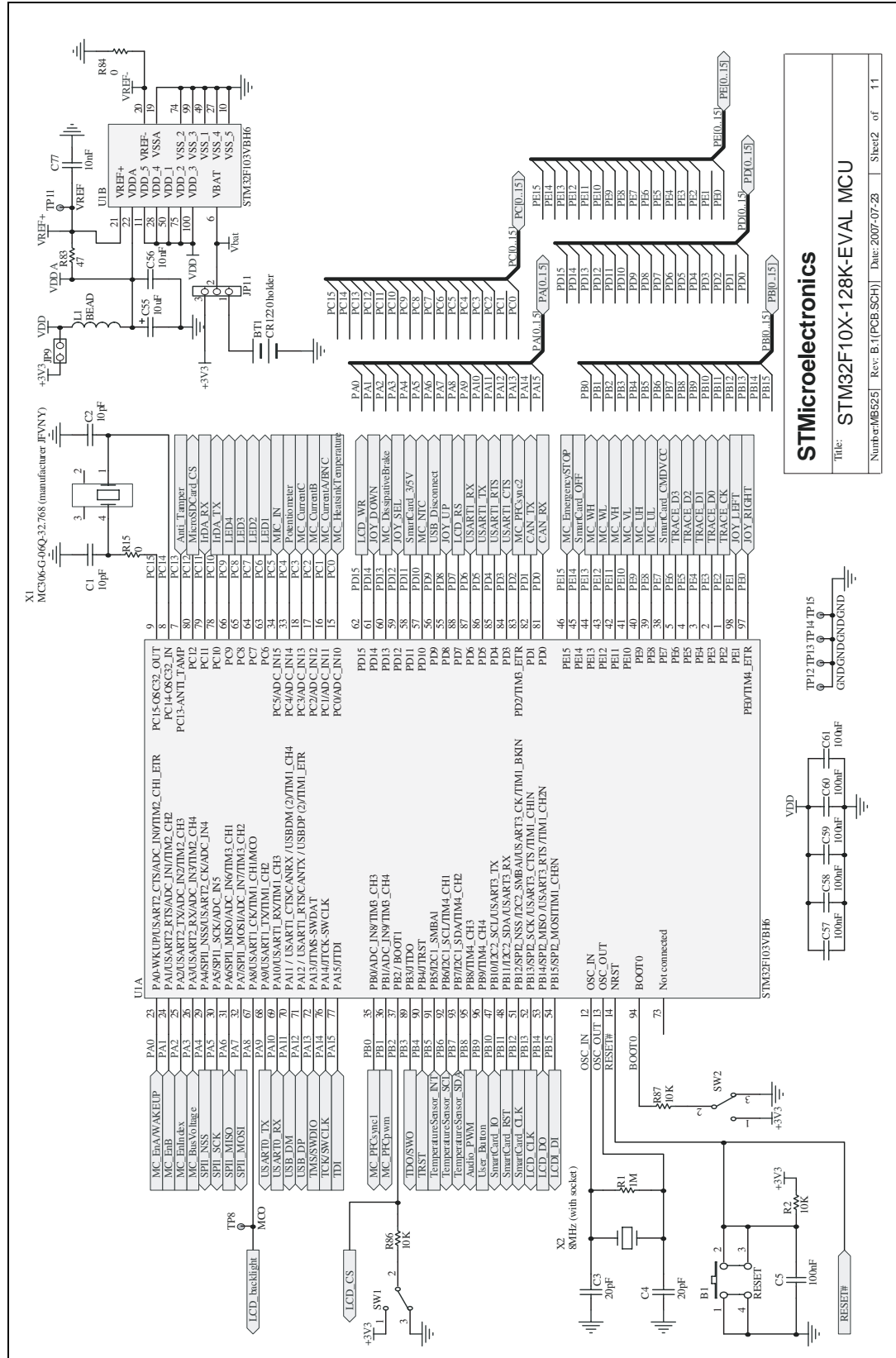
STMicroelectronics

Title: STM32F10X-128K-EVAL

Number: MB525 | Rev: B.1 (POB.SCH) | Date: 2007-06-21 | Sheet 1 of 11



Figure 21. MCU connections

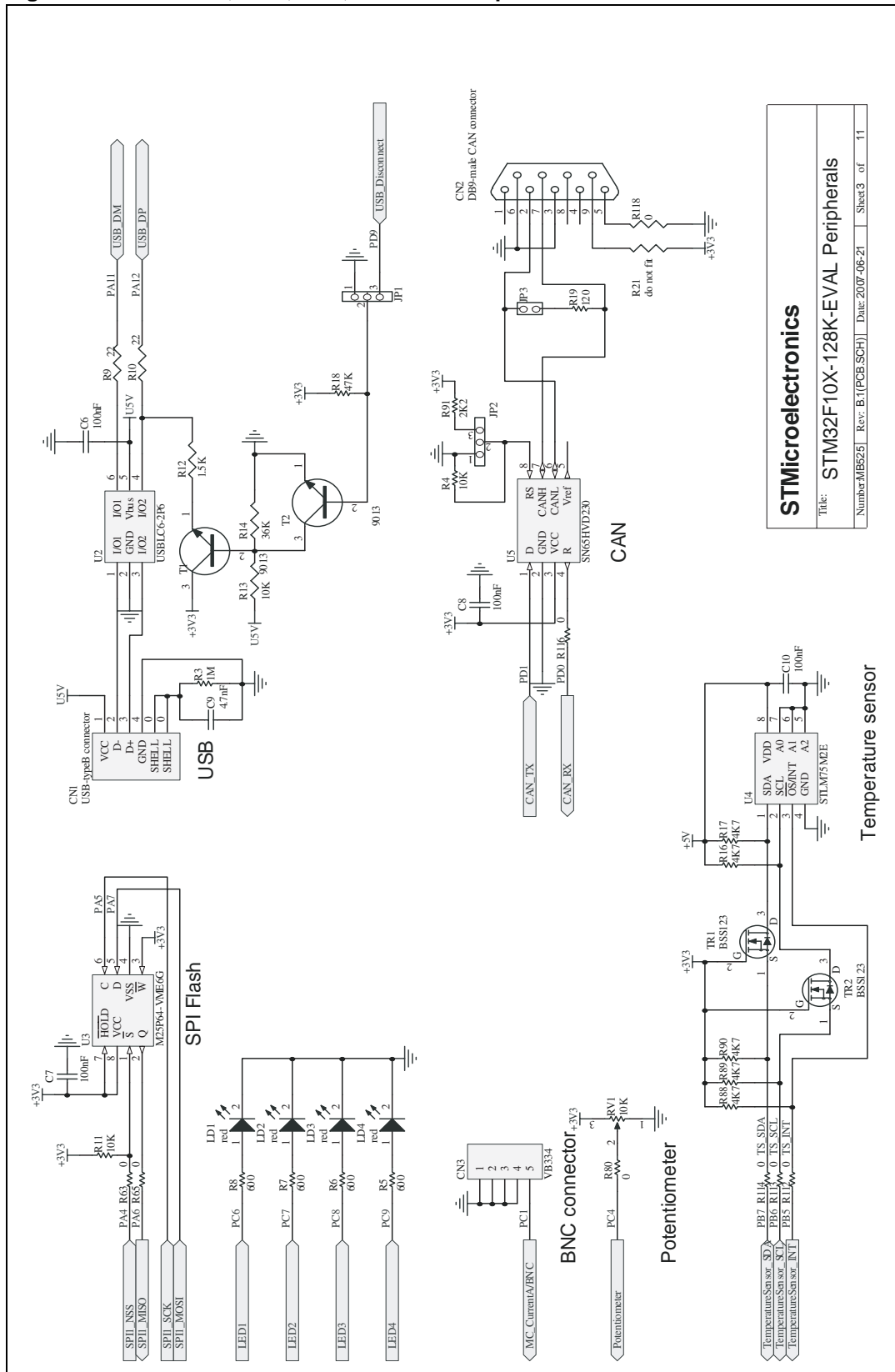


STMicroelectronics

Title: STM32F10X-128K-EVAL MCU

Number: M555 Rev. B.1 (PCB.SCH) | Date: 2007-07-28 | Sheet 2 of 11

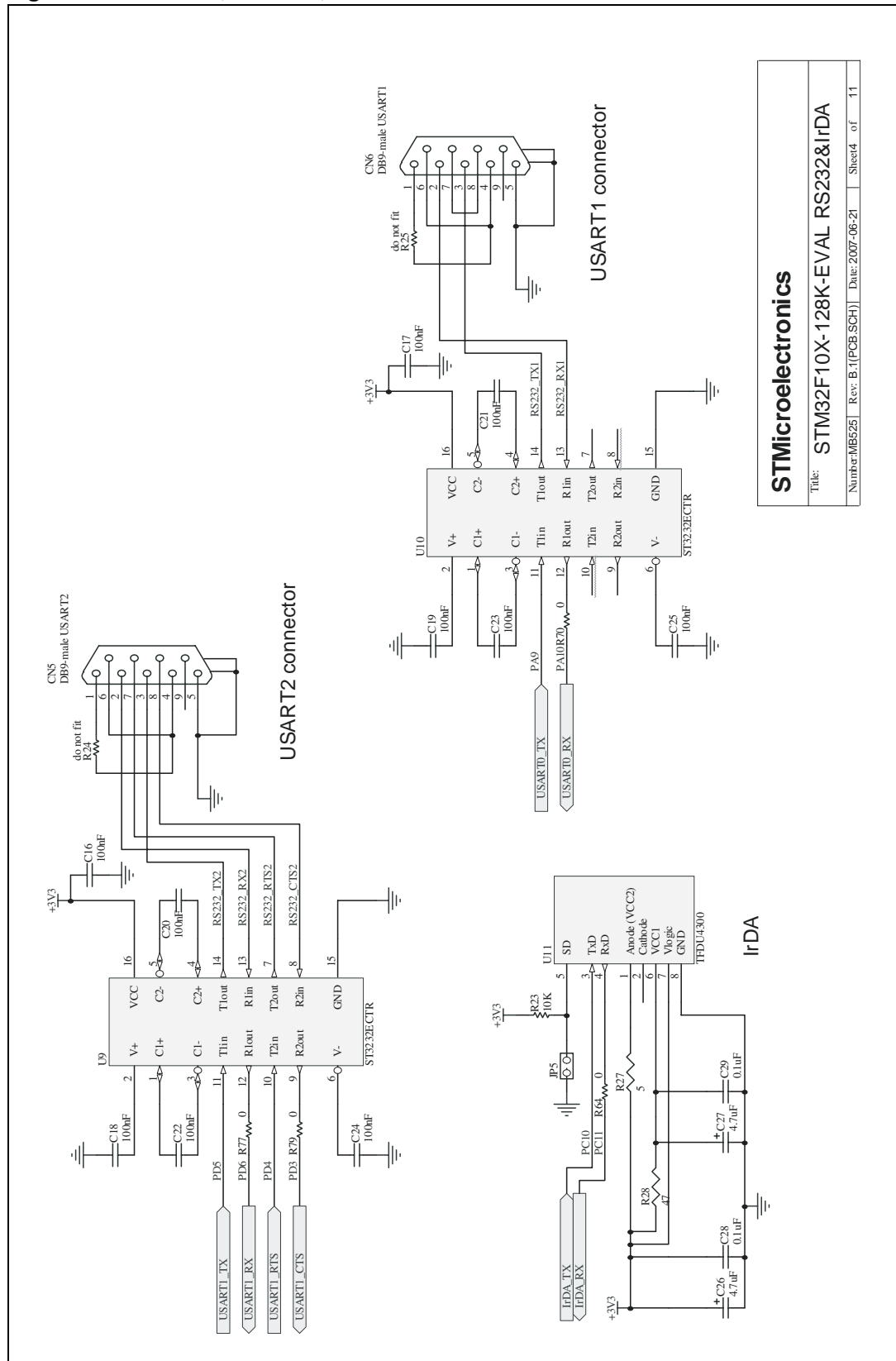
Figure 22. EEPROM, USB, LED, CAN and temperature sensor



STMicroelectronics
 Title: STM32F10X-128K-EVAL Peripherals
 Number: MB525 Rev. B.1(PCB:SGH) Date: 2007-06-21 Sheet 3 of 11

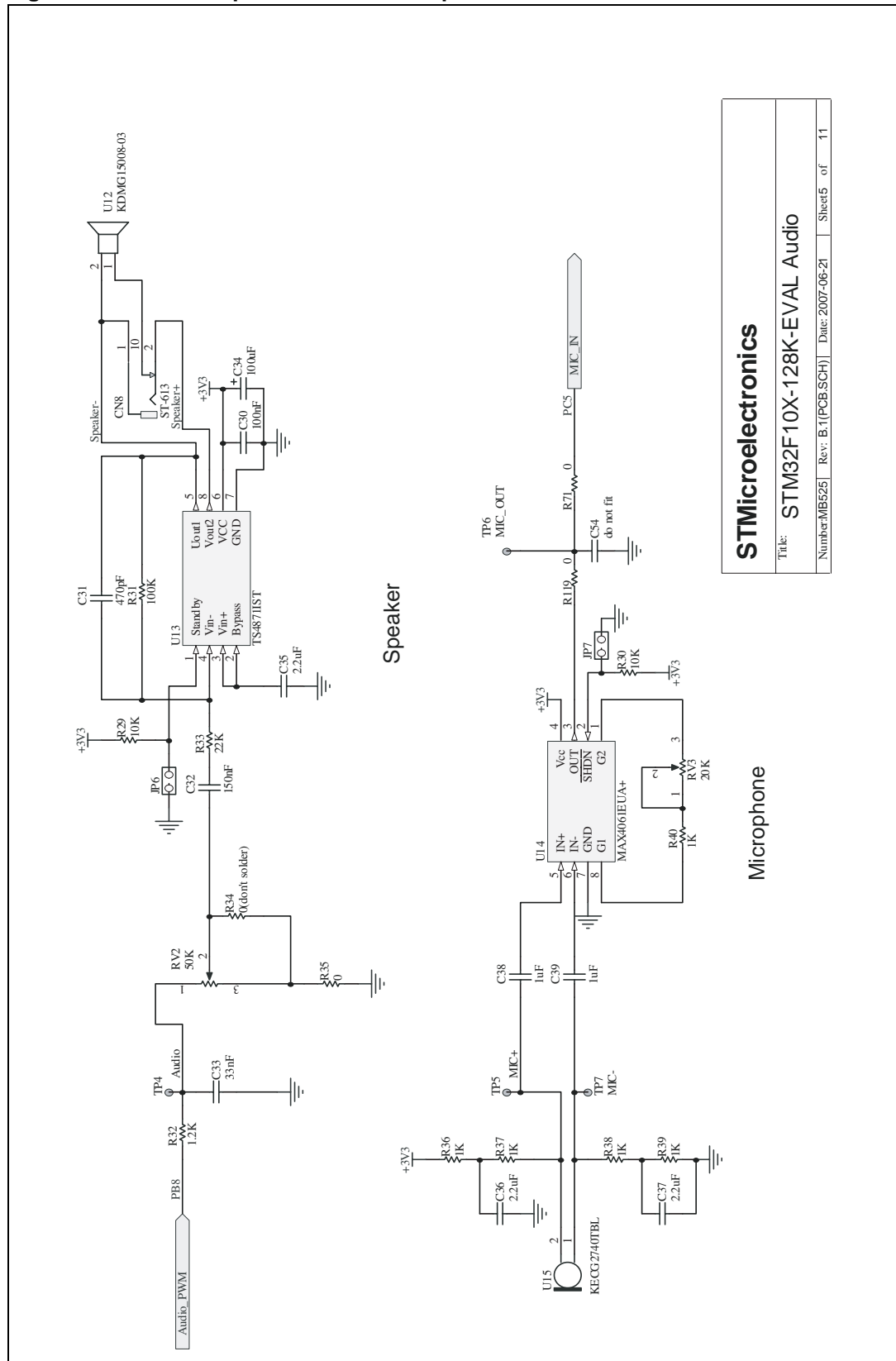


Figure 23. USART1, USART2, IrDA



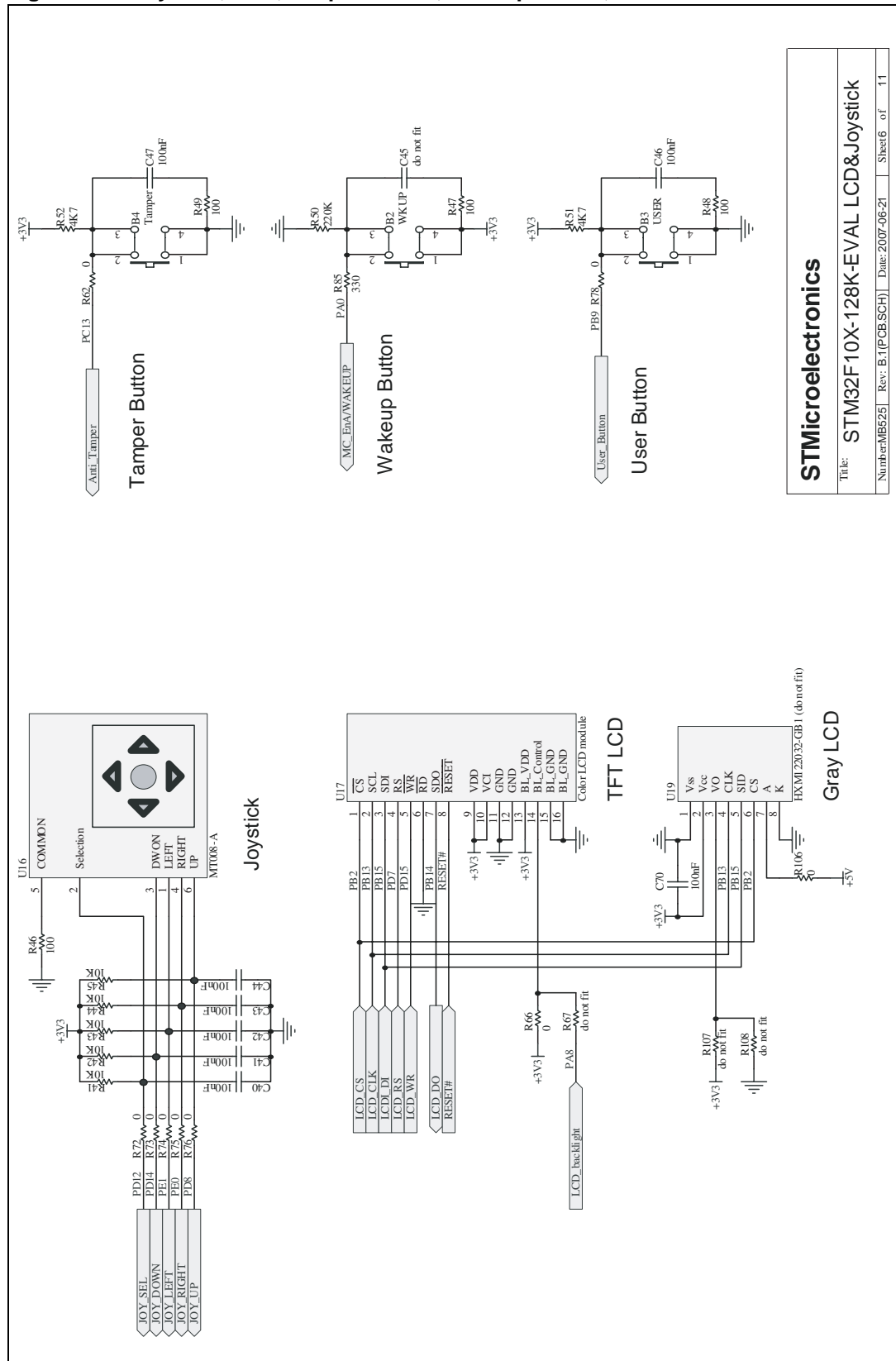
STMicroelectronics	
Title: STM32F10X-128K-EVAL RS232&IrDA	
Number: MB525	Rev: B.1(PCB.SCH)
Date: 2007-06-21	Sheet 4 of 11

Figure 24. Audio amplifier and micro amplifier



STMicroelectronics		
Title: STM32F10X-128K-EVAL Audio		
Number: MB525	Rev: B.1(PCB.SCH)	Date: 2007-06-21
	Sheet 6	of 11

Figure 25. Joystick, LCD, tamper button, wakeup button, user button

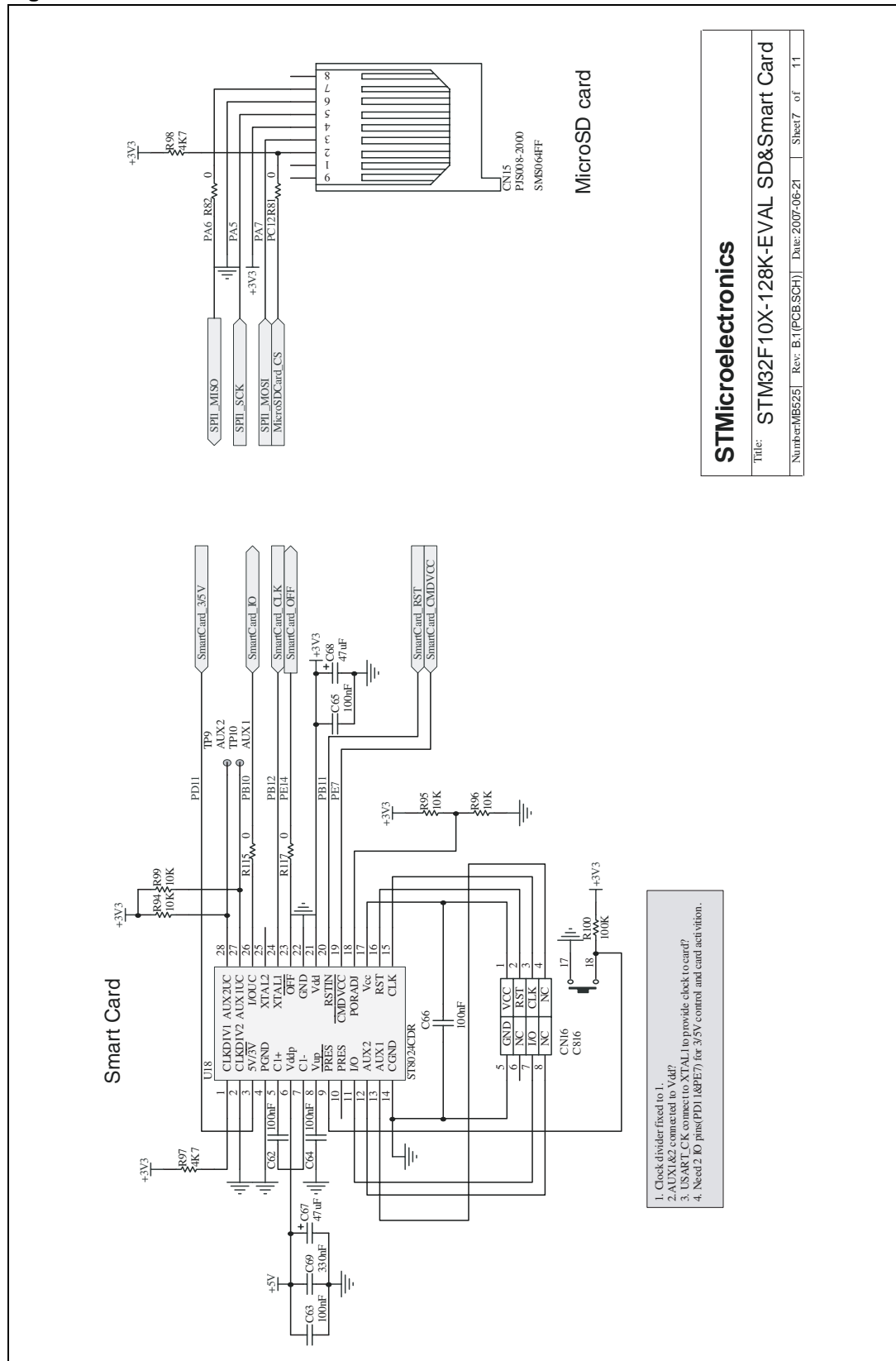


STMicroelectronics

Title: STM32F10X-128K-EVAL LCD&Joystick

Number:MB525 Rev: B.1(PCB[SCH]) Date:2007-06-21 Sheet6 of 11

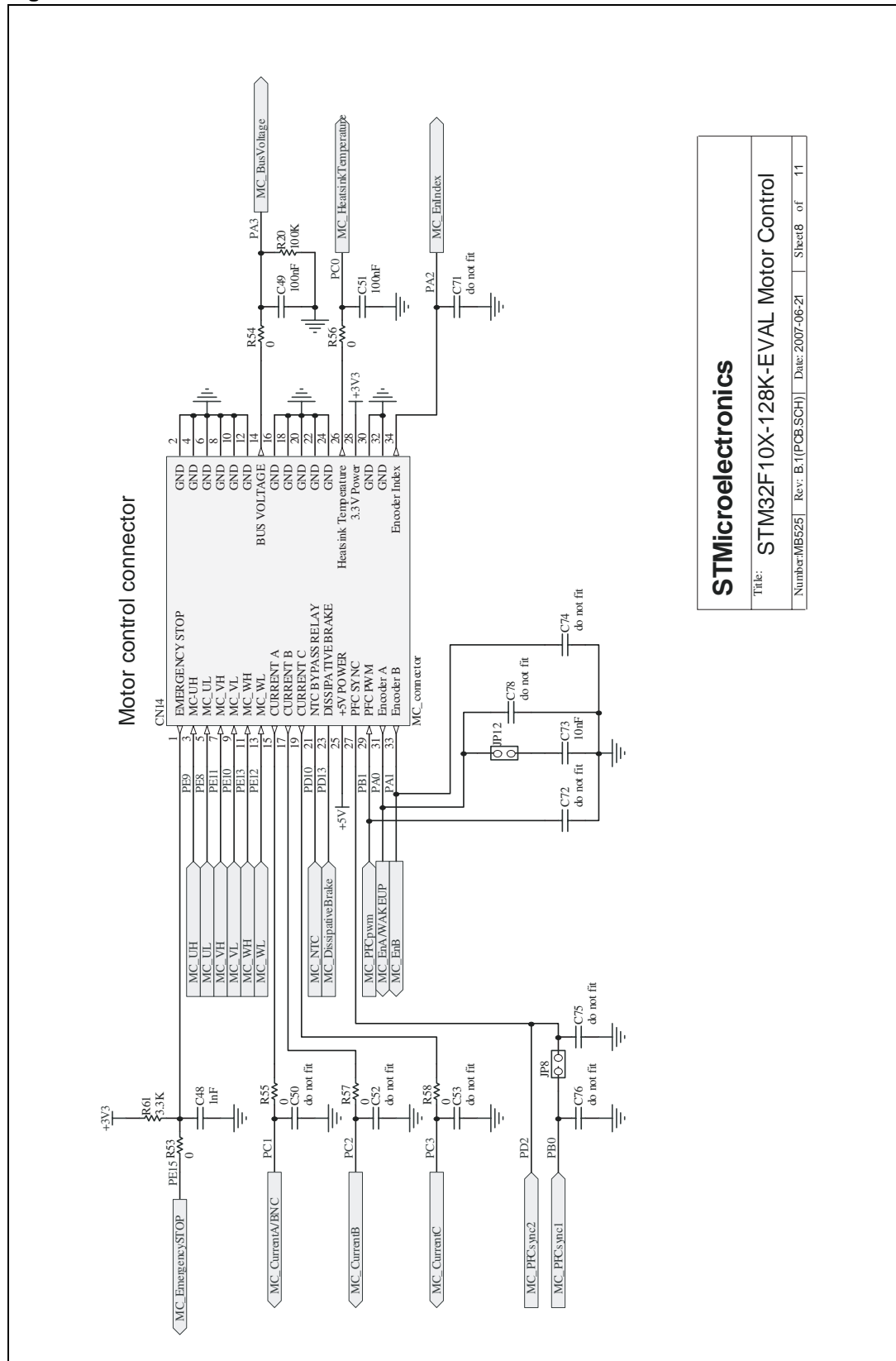
Figure 26. Smartcard and MicroSD card



1. Clock divider fixed to 1.
2. AUX1&2 connected to V4d?
3. USART_CLK connect to XTAL1 to provide clock to card?
4. Need 2 IO pins (PD11 & PE7) for 3.5V control and card activation.

STMicroelectronics		
Title: STM32F10X-128K-EVAL SD&Smart Card		
Number: MB625	Rev: B.1 (PCB.SCH1)	Date: 2007-06-21
		Sheet 7 of 11

Figure 27. Motor control



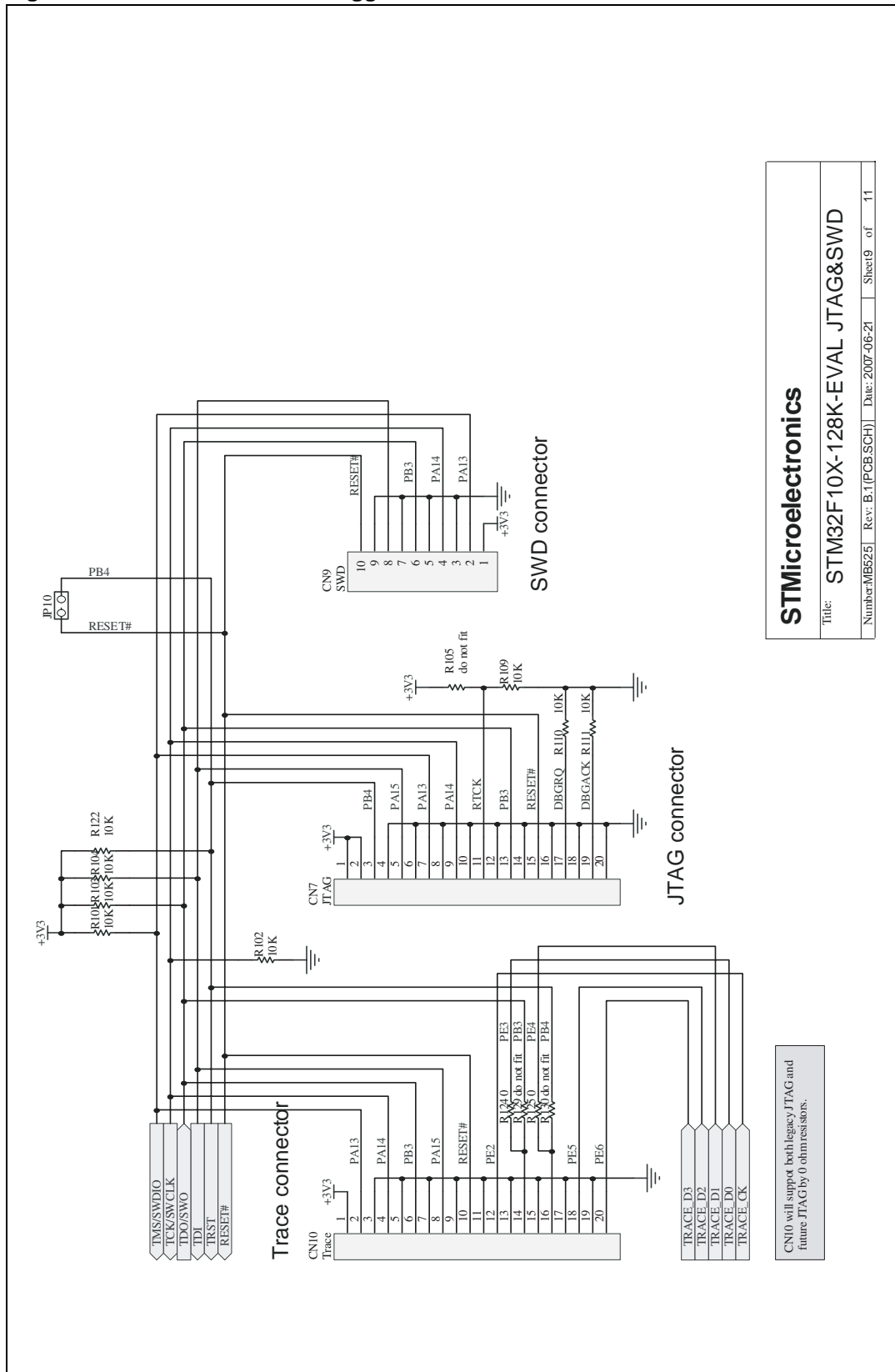
STMicroelectronics

Title: **STM32F10X-128K-EVAL Motor Control**

Number: MB525 | Rev: B.1(PCB_SCH) | Date: 2007-06-21 | Sheet 8 of 11



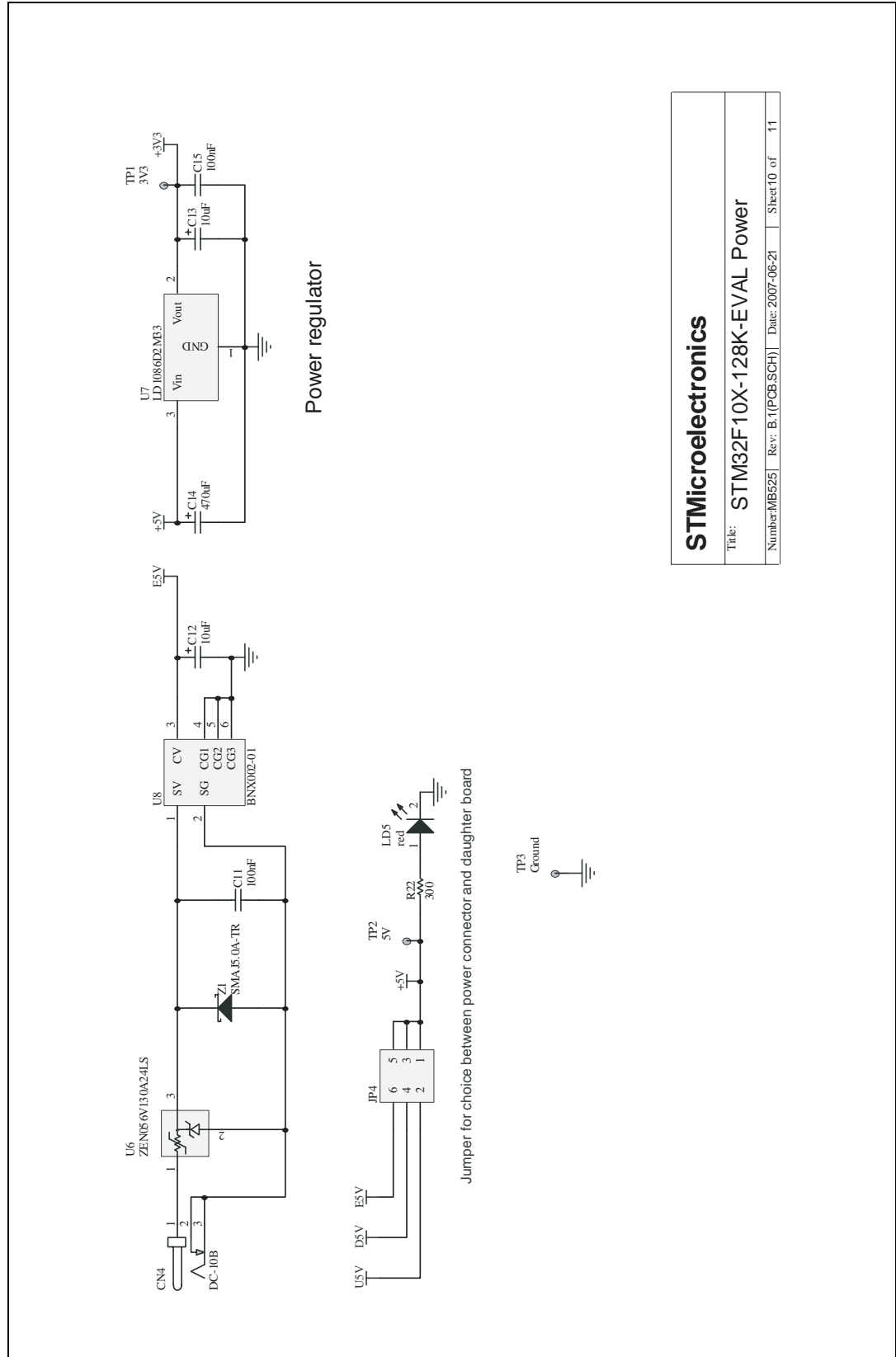
Figure 28. JTAG and SWD debugger



STMicroelectronics
 Title: STM32F10X-128K-EVAL JTAG&SWD
 Number: MB525 | Rev: B.1(PCB.SCH) | Date: 2007-06-21 | Sheet 9 of 11

CN10 will support both legacy JTAG and future JTAG by 0 ohm resistors.

Figure 29. Power supply



STMicroelectronics		
Title: STM32F10X-128K-EVAL Power		
Number: MBS25	Rev: B.1(PCB:SCH)	Date: 2007-06-21
		Sheet 10 of 11

Figure 30. Extension connectors

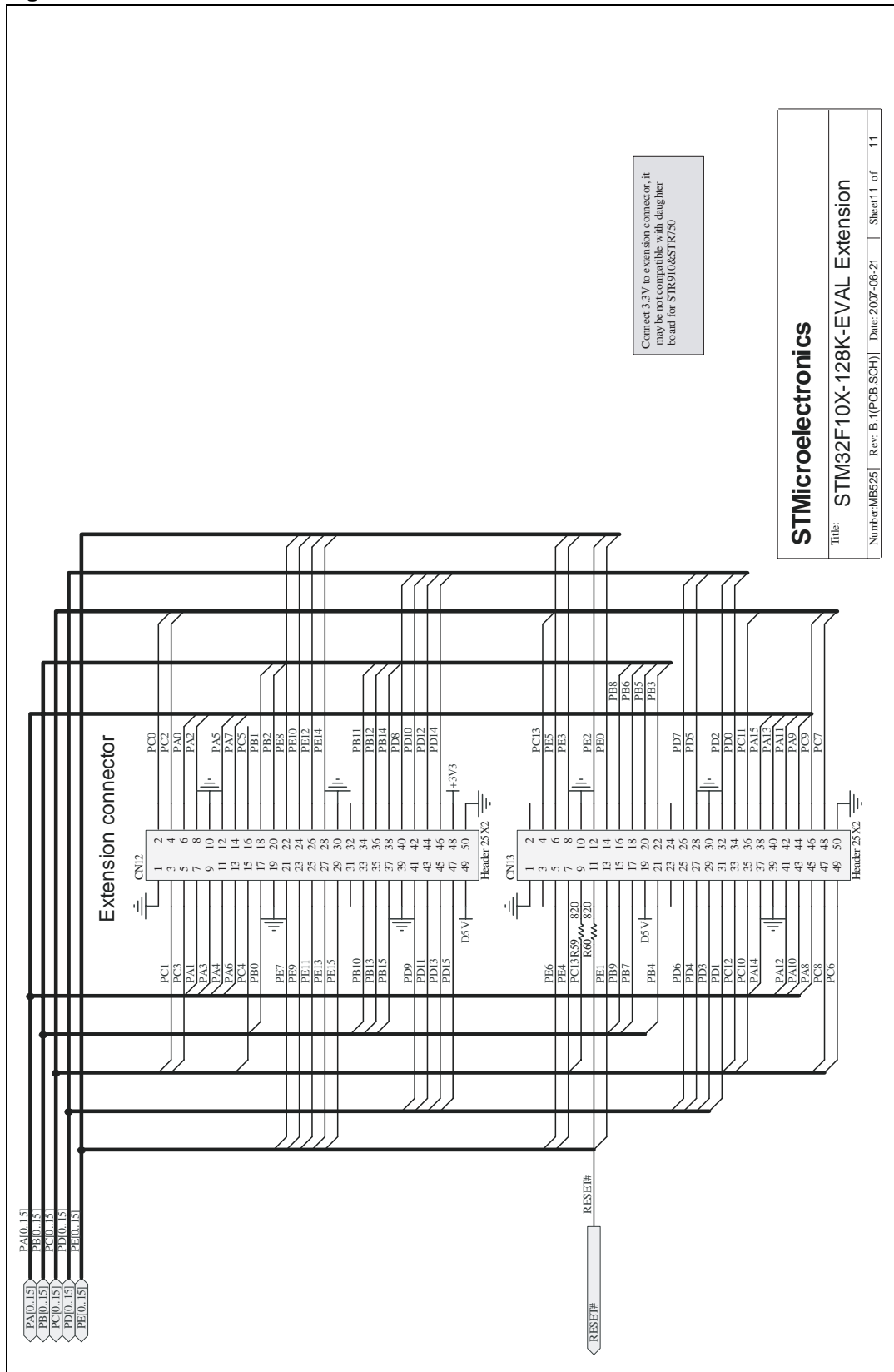
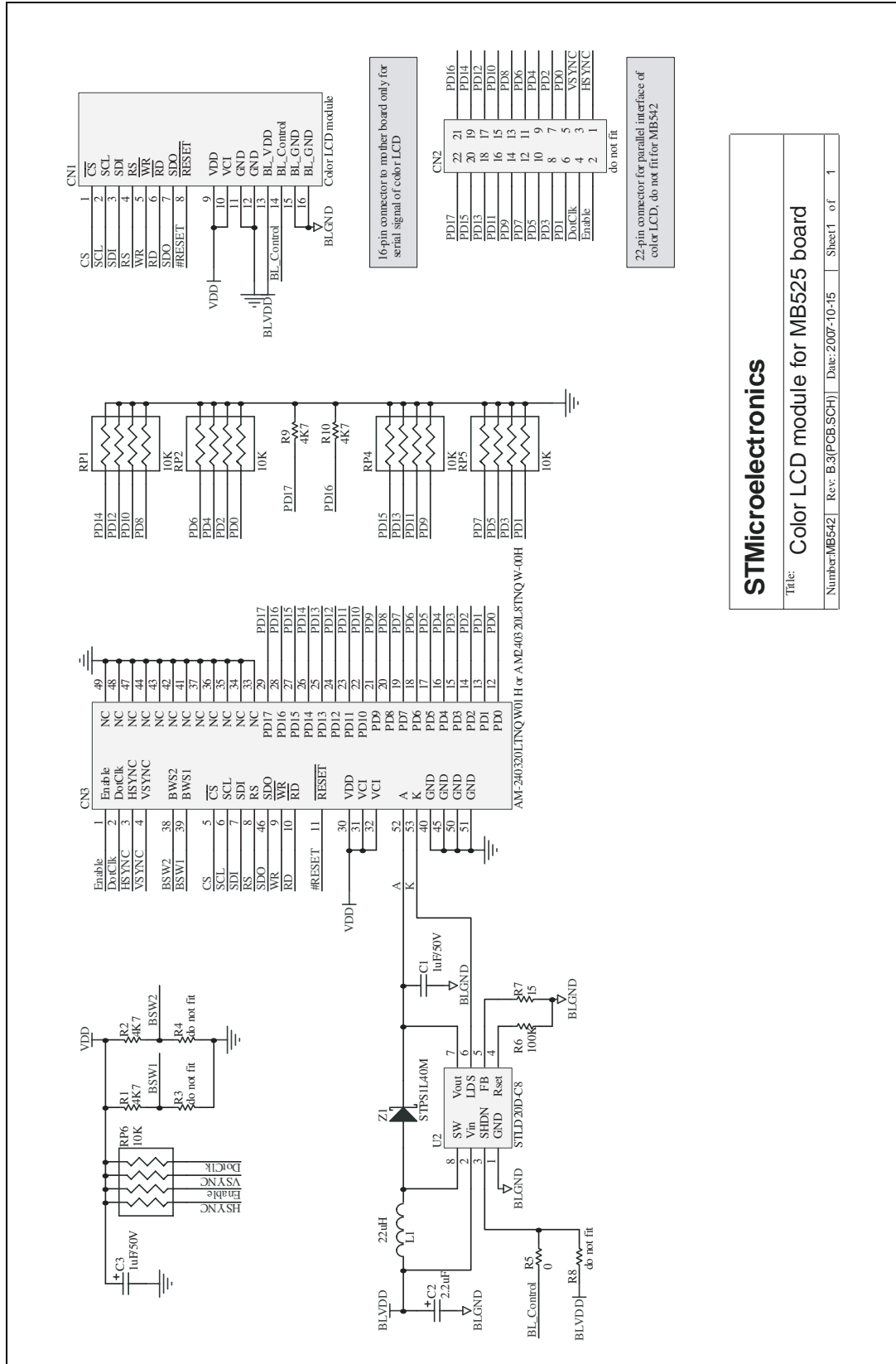


Figure 31. MB542 daughter board schematics



STMicroelectronics
 Title: Color LCD module for MB525 board
 Number: MB542 Rev. B.3(PCB.SCH) Date: 2007-10-15 Sheet 1 of 1

Appendix A STM3210B-EVAL IO assignments

Table 25. Evaluation board IO assignments

LQFP100	Pin name	Type	Level		EVAL board IO assignment
			Input	Output	
1	PE2	I/O	FT		Debug connector
2	PE3	I/O	FT		Debug connector
3	PE4	I/O	FT		Debug connector
4	PE5	I/O	FT		Debug connector
5	PE6	I/O	FT		Debug connector
6	VBAT	S			
7	PC13-ANTI_TAMP	I/O			Anti-tamper button
8	PC14-OSC32_IN	I/O	TC		32K OSC
9	PC15-OSC32_OUT	I/O	TC		32K OSC
10	VSS_5	S			
11	VDD_5	S			
12	OSC_IN	I	TC		
13	OSC_OUT	O	TC		
14	NRST	I/O			RESET#
15	PC0	I/O	TC		MC_ADC10 pin 26
16	PC1	I/O	TC		MC_ADC11 pin 15/BNC connector
17	PC2	I/O	TC		MC_ADC12 pin 17
18	PC3	I/O	TC		MC_ADC13 pin 19
19	VSSA	S			
20	VREF-	S			
21	VREF+	S			
22	VDDA	S			
23	PA0-WKUP	I/O	TC		MC_TIM2_CH1 pin 31/WAKEUP Button
24	PA1	I/O	TC		MC_TIM2_CH2 pin 33
25	PA2	I/O	TC		MC_TIM4_CH3 pin 34
26	PA3	I/O	TC		MC_ADC3 pin 14
27	VSS_4	S			
28	VDD_4	S			
29	PA4	I/O	TC		External Flash

Table 25. Evaluation board IO assignments

LQFP100	Pin name	Type	Level		EVAL board IO assignment
			Input	Output	
30	PA5	I/O	TC		External Flash/Sdcard
31	PA6	I/O	TC		External Flash/Sdcard
32	PA7	I/O	TC		External Flash/Sdcard
33	PC4	I/O	TC		Potentiometer
34	PC5	I/O	TC		Mirco ADC in
35	PB0	I/O	TC		MC_TIM3_CH3 pin 27
36	PB1	I/O	TC		MC_TIM3_CH4 pin 29
37	PB2	I/O	FT		Boot1/ LCD CS
38	PE7	I/O	FT		SmartCard_CMDVCC
39	PE8	I/O	FT		MC_TIM1_CH1N pin 5
40	PE9	I/O	FT		MC_TIM1_CH1 pin 3
41	PE10	I/O	FT		MC_TIM1_CH2N pin 9
42	PE11	I/O	FT		MC_TIM1_CH2 pin 7
43	PE12	I/O	FT		MC_TIM1_CH3N pin 13
44	PE13	I/O	FT		MC_TIM1_CH3 pin 11
45	PE14	I/O	FT		SmartCard_Detect
46	PE15	I/O	FT		MC_STOP pin 1
47	PB10	I/O	FT		SmartCard_IO
48	PB11	I/O	FT		SmartCard_Reset
49	VSS_1	S			
50	VDD_1	S			
51	PB12	I/O	FT		SmartCard_CK
52	PB13	I/O	FT		LCD CLK
53	PB14	I/O	FT		LCD DO
54	PB15	I/O	FT		LCD DI
55	PD8	I/O	FT		JOY_UP
56	PD9	I/O	FT		USB DISCONNECT
57	PD10	I/O	FT		MC_pin21
58	PD11	I/O	FT		SmartCard_3/5V
59	PD12	I/O	FT		JOY_SEL
60	PD13	I/O	FT		MC_TIM4_CH2 pin 23
61	PD14	I/O	FT		JOY_DOWN
62	PD15	I/O	FT		LCD_WR

Table 25. Evaluation board IO assignments

LQFP100	Pin name	Type	Level		EVAL board IO assignment
			Input	Output	
63	PC6	I/O	FT		LED
64	PC7	I/O	FT		LED
65	PC8	I/O	FT		LED
66	PC9	I/O	FT		LED
67	PA8	I/O	FT		LCD backlight control
68	PA9	I/O	FT		USART1 TX
69	PA10	I/O	FT		USART1 RX
70	PA11	I/O	FT		USB DM
71	PA12	I/O	FT		USB DP
72	PA13	I/O	FT		Debug TMS
73	NC				
74	VSS_2	S			
75	VDD_2	S			
76	PA14	I/O	FT		Debug TCK
77	PA15	I/O	FT		Debug TDI
78	PC10	I/O	FT		IRDA TX
79	PC11	I/O	FT		IRDA RX
80	PC12	I/O	FT		SD CS
81	PD0	I/O	FT		CAN RX
82	PD1	I/O	FT		CAN TX
83	PD2	I/O	FT		MC_TIM3_ETR pin 27
84	PD3	I/O	FT		USART2 CTS
85	PD4	I/O	FT		USART2 RTS
86	PD5	I/O	FT		USART2 TX
87	PD6	I/O	FT		USART2 RX
88	PD7	I/O	FT		LCD_RS
89	PB3	I/O	TC		Debug TDO
90	PB4	I/O	TC		Debug TRST
91	PB5	I/O	TC		Temperature SMBIA
92	PB6	I/O	FT		Temperature SCL
93	PB7	I/O	FT		Temperature SDA
94	BOOT0	I			
95	PB8	I/O	FT		Audio PWM

Table 25. Evaluation board IO assignments

LQFP100	Pin name	Type	Level		EVAL board IO assignment
			Input	Output	
96	PB9	I/O	FT		User Button
97	PE0	I/O	FT		JOY_RIGHT
98	PE1	I/O	FT		JOY_LEFT
99	VSS_3	S			
100	VDD_3	S			

Revision history

Date	Revision	Changes
2-May-2006	1	Initial release.
23-May-2007	2	Corrected product name: used to be STM32F10X-128K-EVAL, now STM3210B-EVAL.
22-Aug-2007	3	Default setting for jumper JP1 corrected in Table 10: USB jumpers . Schematics updated in Section 3: Schematics . Corrected error in Table 20: Daughter board extension connector CN12 . The functions of pin 8 and pin 46 were inverted.
29-Oct-2007	4	Added LCD description in Section 1.1: LCD configuration on page 7 .

Please Read Carefully:

Information in this document is provided solely in connection with ST products. STMicroelectronics NV and its subsidiaries ("ST") reserve the right to make changes, corrections, modifications or improvements, to this document, and the products and services described herein at any time, without notice.

All ST products are sold pursuant to ST's terms and conditions of sale.

Purchasers are solely responsible for the choice, selection and use of the ST products and services described herein, and ST assumes no liability whatsoever relating to the choice, selection or use of the ST products and services described herein.

No license, express or implied, by estoppel or otherwise, to any intellectual property rights is granted under this document. If any part of this document refers to any third party products or services it shall not be deemed a license grant by ST for the use of such third party products or services, or any intellectual property contained therein or considered as a warranty covering the use in any manner whatsoever of such third party products or services or any intellectual property contained therein.

UNLESS OTHERWISE SET FORTH IN ST'S TERMS AND CONDITIONS OF SALE ST DISCLAIMS ANY EXPRESS OR IMPLIED WARRANTY WITH RESPECT TO THE USE AND/OR SALE OF ST PRODUCTS INCLUDING WITHOUT LIMITATION IMPLIED WARRANTIES OF MERCHANTABILITY, FITNESS FOR A PARTICULAR PURPOSE (AND THEIR EQUIVALENTS UNDER THE LAWS OF ANY JURISDICTION), OR INFRINGEMENT OF ANY PATENT, COPYRIGHT OR OTHER INTELLECTUAL PROPERTY RIGHT.

UNLESS EXPRESSLY APPROVED IN WRITING BY AN AUTHORIZED ST REPRESENTATIVE, ST PRODUCTS ARE NOT RECOMMENDED, AUTHORIZED OR WARRANTED FOR USE IN MILITARY, AIR CRAFT, SPACE, LIFE SAVING, OR LIFE SUSTAINING APPLICATIONS, NOR IN PRODUCTS OR SYSTEMS WHERE FAILURE OR MALFUNCTION MAY RESULT IN PERSONAL INJURY, DEATH, OR SEVERE PROPERTY OR ENVIRONMENTAL DAMAGE. ST PRODUCTS WHICH ARE NOT SPECIFIED AS "AUTOMOTIVE GRADE" MAY ONLY BE USED IN AUTOMOTIVE APPLICATIONS AT USER'S OWN RISK.

Resale of ST products with provisions different from the statements and/or technical features set forth in this document shall immediately void any warranty granted by ST for the ST product or service described herein and shall not create or extend in any manner whatsoever, any liability of ST.

ST and the ST logo are trademarks or registered trademarks of ST in various countries.

Information in this document supersedes and replaces all information previously supplied.

The ST logo is a registered trademark of STMicroelectronics. All other names are the property of their respective owners.

© 2007 STMicroelectronics - All rights reserved

STMicroelectronics group of companies

Australia - Belgium - Brazil - Canada - China - Czech Republic - Finland - France - Germany - Hong Kong - India - Israel - Italy - Japan - Malaysia - Malta - Morocco - Singapore - Spain - Sweden - Switzerland - United Kingdom - United States of America

www.st.com